



Roll-A-Grille™

19mm ALUMINIUM ROLLER GRILLE



The B&D Roll-A-Grille™ 19mm Industrial Grille Type Aluminium Shutter is specifically designed from aluminium extrusion to provide a high level of security while maintaining the feel of openness between the internal and external spaces.

The B&D Roll-A-Grille 19mm is recommended for applications such as retail shopfronts, secure parking structures, arcades, sporting complexes, clubs, bars and counter tops. The B&D Roll-A-Grille 19mm is a cost efficient product for spaces where ventilation is required or continual visual product branding is desirable.

The B&D Roll-A-Grille 19mm can be supplied in a vast range of sizes and colour finishes.

RECOMMENDED APPLICATION

- Ideal for shopping centre shopfronts, secure parking structures, sporting complexes and clubs
- Suitable for openings ranging from 100mm to 1000mm (h) and up to 8000mm (w)
- High level of security.

BOTTOM RAILS

The B&D Roll-A-Grille 19mm is supplied with a sturdy T-Rail aluminium bottom rail which provides additional strength to the door. This bottom rail may be supplied with an optional weather seal.

ROLLER DRUM

165mm or 229mm Spiral drum rotating on a 34mm heavy duty shaft fitted with high speed industrial bearing & helical springs to counterbalance the door in accordance with the manufacturers specifications.



Doors & Openers®

THERE'S SO MUCH MORE BEHIND A B&D DOOR

Call 13 62 63 or visit www.bnd.com.au for further information.

THERE'S SO MUCH MORE BEHIND A DOOR

CURTAIN

19mm Aluminium extrusion tubing at 75mm centres interconnected with 35mm x 3mm links spaced at 500mm centres. Each aluminium section is fitted with nylon plugs to reduce friction.

OPERATION

The B&D Roll-A-Grille 19mm can be either manually operated or motorised depending upon size requirements. There are a range of electric motors available depending on application and usage.

SPRING ASSISTED DRUM ASSEMBLY

The spring assisted counterbalanced roller drum is fabricated from high quality steel spiral ducted tube or spiral welded tube. The central shaft carries helical springs to ensure smooth and effortless operation.

VERSATILE TRACKING SYSTEM

The 100mm x 38mm aluminium door tracks can be mounted between wall fix or behind wall fix. The guides can also accommodate a rubber twin fin extrusion or mohair felt buffer to ensure a quieter operation. Manual doors only are fitted with door stops.

LOCKING

The B&D Roll-A-Grille 19mm may be fitted with a centrally mounted locking mechanism within the bottom rail. The locking mechanisms are generally concealed behind extruded polycarbonate covers for aesthetics and tamper proofing. Locking is not recommended for motorised doors.

SECURITY

The B&D Roll-A-Grille 19mm is constructed from 19mm aluminium extrusion tubing connected with 35mm links creating a symmetrical brick-like pattern. This grille allows retailers to retain visual product branding while their products remain secure.

DIMENSIONS (all measurements in mm)

DOOR HEIGHT	DRUM 165MM		DRUM 229MM	
	ROLL DIAMETER	CENTRE AXLE FROM WALL	ROLL DIAMETER	CENTRE AXLE FROM WALL
1000	326	173	326	173
1500	326	173	378	199
2000	330	175	394	207
2500	364	192	398	209
3000	378	200	434	227
3500	415	218	448	234
4000	435	228	453	237
4500	460	240	470	245

CLEARANCES

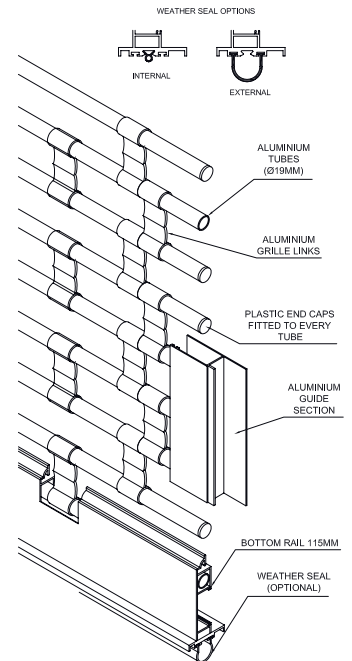
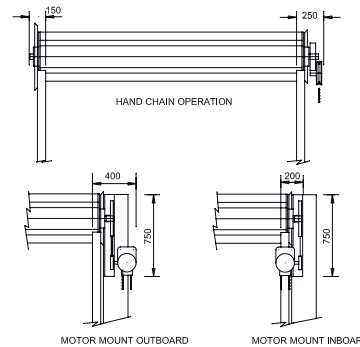
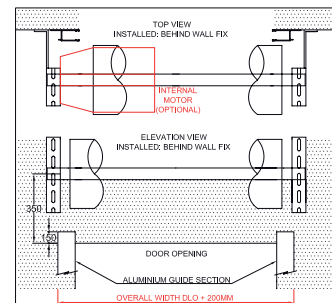
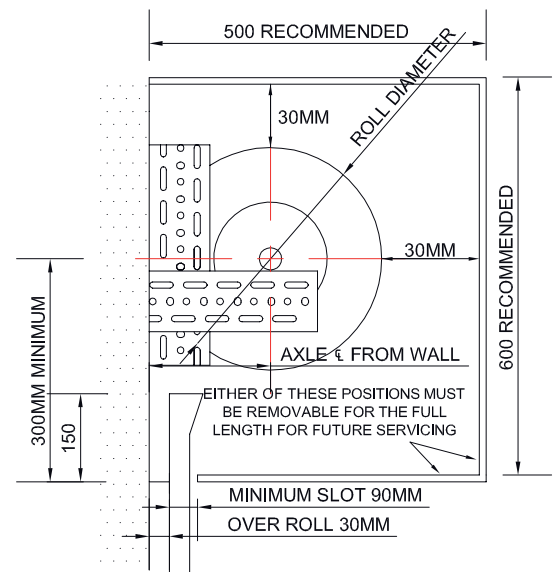

WARRANTY

A 12 month limited material, labour and workmanship warranty applies.

B&D Doors has offices servicing all states. For more details on this product or our other ranges, phone **13 62 63** or visit www.bnd.com.au

Notes / Information

- B&D Roll-A-Grille™ 19mm Industrial Grille Type Aluminium Shutters are covered by a 12 month warranty, for complete door and parts, as recommended in the door's handbook. Full details of the warranty are available from www.bnd.com.au. 12 month warranty only applies to doors purchased and installed in Australia & New Zealand. Warranty only valid if warranty conditions are met.
- For areas within one kilometre of a corrosive environment eg. salt air or industrial fallout, special care and maintenance are generally required. Consult B&D or your B&D Accredited Dealer for advice.
- The company reserves the right to make changes or improvements to the products or accessories without notice and without incurring any obligation to make similar changes or improvements to goods previously ordered. Specifications subject to change without notice.



Doors & Openers®

THERE'S SO MUCH MORE BEHIND A B&D DOOR

Call **13 62 63** or visit www.bnd.com.au for further information.

B&D Doors is a division of B&D Australia Pty Ltd, ABN 25 010 473 971 © 2014 B&D Australia