

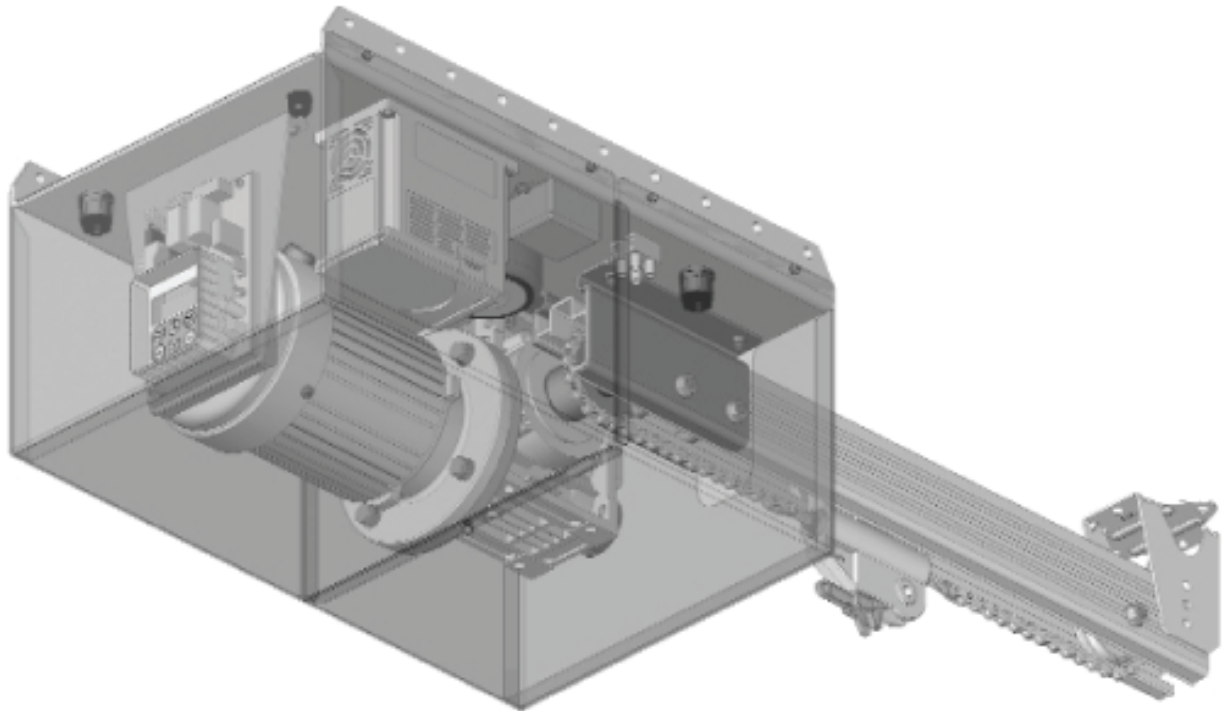

Axess® Pro Series 1101

Commercial Overhead Door Opener



Featuring **TrioCode™** Technology

automatic
TECHNOLOGY

smart | simple | secure



WARNING: It is vital for the safety of persons to follow all instructions. Failure to comply with the installation instructions and the safety warnings may result in serious personal injury and/or property and remote control opener damage. Please save these instructions for future reference.

NOTE: A Photo Electric Beam Sensor must be fitted with this opener. Failure to comply will void the warranty and may cause serious personal injury and/or property damage.

Automatic Technology (Australia) Pty Ltd to the extent that such may be lawfully excluded hereby expressly disclaims all conditions or warranties, statutory or otherwise which may be implied by laws as conditions or warranties of purchase of an Automatic Technology (Australia) Pty Ltd automatic opener. Automatic Technology (Australia) Pty Ltd hereby further expressly excludes all or any liability for any injury, damage, cost, expense or claim whatsoever suffered by any person as a result whether directly or indirectly from failure to install the Automatic Technology (Australia) automatic opener in accordance with these installation instructions.



Axess® Pro Series 1101

Commercial Overhead Garage Door Opener

Important Safety Instructions	4
Features	6
Product Description	8
Before Drive Unit Installation	8
Drive Unit Installation	9
Control Board Layout	10
Wiring Diagram	12
Setting Travel Limits	13
Setting Pedestrian Position	15
Setting Operating Speed	15
Description Of Standard Operation	16
Parameter Viewing And Editing	17
Menu Structure	18
Control Board Adjustments	19
Menu 2 Obstruction Margin	19
Menu 3 Auto-close Times	19
Menu 4 Lock Times	20
Menu 5 Light Times	20
Menu 6 Motor Settings	21
Menu 7 Operating Modes	21
Coding Transmitters	23
Transmitter Edit Procedure	24
Transmitter Management	25
Code Operation (Location Empty)	26
Code Operation (Location Used)	26
Delete Operation	26
Edit Operation	26
Copy Operation	26
Remote Code Set Procedure	27
Diagnostic Tools	28
Menu 8.1 Test Inputs	28
Menu 8.2 Test Tx'ers	28
Menu 8.3 Display History	28
Menu 8.4 Memory Usage	29
Menu 8.5 Service Counter	29
Menu 8.6 Counters	29
Menu 8.7 Installation	29
Memory Tools	30
Menu 9.1 Clr Control	30
Menu 9.2 Clr Tx'ers	30
Accessories Installation	30
Solenoid Or Magnetic Lock	30
Courtesy Light	30
PE Beams	31
Troubleshooting	32
System Specifications	33
Parts List	34
Warranty And Exclusion Of Liability	38





Important Safety Instructions

WARNING: It is vital for the safety of people to follow all instructions. Failure to comply with the following Safety instructions may result in serious personal injury and/or property damage.

For **Safety** protection, a Photo Electric Beam **must** be fitted with this opener. Failure to comply will void the warranty and may result in serious personal injury and/or property damage.

DO NOT operate the opener unless the door is in full view and free from objects such as cars and children/people. Make sure that the door has finished moving before entering or leaving the driveway.

DO NOT operate the opener when children/people are near the door. Children must be supervised near the door at all times when the opener is in use. **Serious personal injury** and/or property damage can result from failure to follow this warning.

DO NOT allow children to operate the opener. **Serious personal injury and/or property damage** can result from failure to follow this warning.

Make sure that the **Safety Obstruction detection** system is working correctly, and is **tested** every month. Test as per the Installation Instructions Manual. Adjust if necessary and recheck. Failure to follow this rule could result in **serious personal injury** and/or property damage. This test must be repeated at regular intervals and the necessary adjustments made as required.

If using a key switch or keypad or any device that can operate the opener, make sure it is out of reach of children and that the doorway is in full view at all times.

Make sure that transmitters are kept out of reach of children. **Warning** - It is vital for the safety of people to follow all instructions.



Important Safety Instructions

Please read this installation instruction manual before attempting to install or use the opener. Failure to comply with the instructions may result in serious injury and/or property damage.

The opener is not showerproof - it should not be immersed in water or sprayed directly by a hose or other water carrying device.

The door must be **well balanced** and in good working order. A faulty door must be repaired by a qualified technician prior to opener installation.

Remove or disengage all locks and mechanisms prior to installation of the opener.

Keep hands and loose clothing **clear** of the door and opener at all times.

When using Auto-Close mode a **photo electric beam** must be fitted correctly and tested for operation at regular intervals. **Extreme caution** is recommended when using Auto-Close mode. **All safety rules** above must be followed.

In order for the opener to **SENSE** an object obstructing the doorway, some **force** must be exerted on the object. As a result the object, door and/or person may suffer **damage or injury**.

Make sure that the door is fully open before driving into or out of the driveway. And make sure the door is fully closed before leaving the driveway.

The opener is not intended for use by young children or infirm persons without adequate supervision. Children should be supervised to ensure that they do not play with the transmitters or the opener.

Frequently examine the installation, in particular guides and mountings for signs of wear, damage or imbalance. **DO NOT** use if repair or adjustment is needed since a fault in the installation or an incorrectly balanced door may cause injury.





Features

Thank you for purchasing the Axess® Pro Series 1101 Commercial Overhead Door Opener. This opener is designed to suit commercial heavy duty panel or sectional doors. The components and materials used in this opener are of the latest technology and highest quality. Listed below are some of the many features.

Operation

To operate the door opener, simply activate one of the integrated controller's inputs by using TrioCode™ handheld transmitter, keypad or other devices including key switches, swipe cards, and loop detectors. In response, the door will then open, stop or close as requested. The opener can also be configured to close automatically using one of several Auto-Close modes.

Operator Console

Incorporated into the integrated controller is a simple to use operator console which consists of several buttons and a display. The console offers a user friendly menu system that greatly simplifies installation, adjustment and status indication. Features include editing transmitter storage and names, setting various parameters, selecting specialised operating modes and performing system diagnostics.

Status Indication

The status of the door opener can be determined at anytime by observing the console's screen. When the MAIN SCREEN is displayed, the current position of the door or the result of the last movement can be found. The display will also show the count down progress of the Auto-Close timers. Any active input will also be displayed along with the state of various features such as periodic service.

TrioCode™ Code Hopping Technology

Every time a TrioCode™ transmitter is used, a new security code is randomly generated from over 4.29 billion possibilities. This greatly enhances the security of the system and makes "code grabbing" a thing of the past.

These transmitters also overcome interference issues by simultaneously sending a signal over three slightly different frequencies. Even if two of the three signals are jammed, the system will still work.





Security Code Store

The opener uses state of the art technology in storing your selected transmitter codes. Up to 511 different transmitters can be stored in the opener's memory with the facility to assign a 11 character name to each transmitter.

Remote Limits Positioning

During installation, a hand held transmitter can be used when setting the door travel limits. This allows the installer to closely observe and control the movement of the door from any position rather than having to be within arms reach of the console.

Controlling Lock And Lights

The controller has dedicated outputs for operating an electric lock and warning or courtesy lights. The timing of these outputs can be adjusted to suit your needs.

Extensive Operating Modes Via Control Inputs And Remote Control

The integrated controller can be configured to operate in many different ways via its 7 control and safety inputs. These include P.E, OPEN, STOP, CLOSE, OSC, SWIPE and PEDESTRIAN. Remote control operation is provided with each transmitter's button being able to be configured to operate one of OSC, PEDESTRIAN, SWIPE, CLOSE, OPEN, STOP, LIGHT or VACATION functions. The controllers functionality is further enhanced by 4 Auto-Close modes, 3 P.E response modes and 2 pedestrian response modes. For details refer to relevant sections.

Manual Operation

The opener is equipped with a unique manual operation device. If power to the opener is disrupted for any reason, the shuttle can be disengaged and the door can move manually. When power is restored, simply re-engage the shuttle to resume automatic operation.





Product Description

fig 01

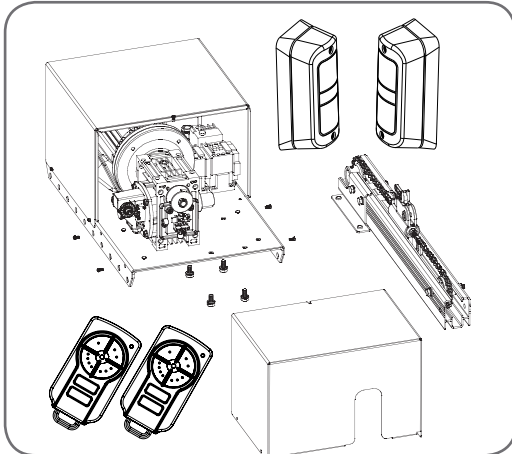

The Axess® Pro Series 1101 Overhead Door Opener consists of a drive unit with integrated logic controller, aluminium channel and photo electric beam sensors.

Logic Controller

Housed alongside the drive motor and gearbox is a set of inverter and intelligent logic controller with menu driven LCD display. The controller offers a range of trigger inputs and door operation parameters. A standard 240V AC power outlet is required to power this model.

Mechanical Drive Unit

The drive unit consists of a powerful three phase motor, rugged cast aluminium gearbox and position encoder. The aluminium track has a channel for running cables for PE Beams etc.

Before Drive Unit Installation

fig 02

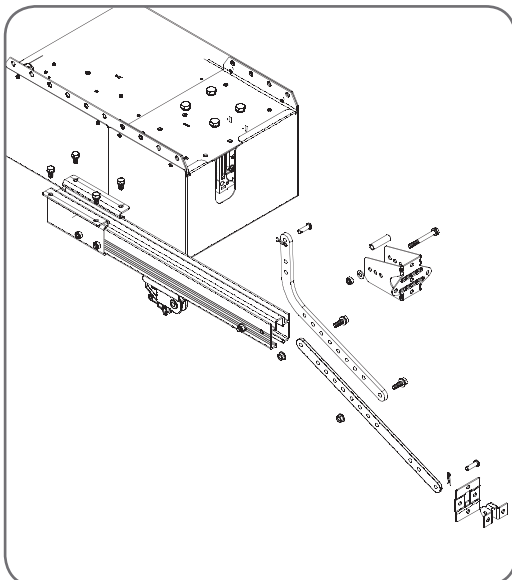

The Axess® Pro Series 1101 Overhead Door Opener is designed to operate most commercial heavy duty and heavy residential overhead doors. The doors must be in good working condition and travel freely in the guides.

Initial Check

Before commencing installation check the following:

1. The door moves freely for the full travel in both directions.
2. The mounting must be solid construction (concrete, brick or steel). It must be able to withstand the full force applied to the door.
3. There is a 240V 10 Amp power point located within one metre of drive unit.
4. Photo-electric Beams must be installed. They should be located as close to the door as practicable.



Drive Unit Installation

Drive Unit Pre-assembly

The drive unit and track assembly are supplied as two separate parts. The drive sprocket is part of the track assembly.

1. To connect track to the drive unit, remove the front cover.
2. Disconnect the trolley from the chain index (**Fig. 02**).
3. Loosen tension on the chain. Do not disconnect the chain.
4. Locate the sprocket keyway with keyway on the Reducer and slide it in place until the face of sprocket boss sits against the shoulder on drive shaft of the reducer.

NOTE: The whole track has to slide with the sprocket. It can be knocked on with a mallet or "helped" with a screwdriver.

5. Once the sprocket is in position, lock cap head screw.
6. Secure the track to drive unit using M8 x 14 Hex Head screws.
7. Tighten the chain and lock it with lock nuts.

Mounting The Drive Unit

1. Determine the centre of the door and mark this point on the wall above (**Fig. 03**).
2. Raise the door to the open position (**Fig. 04**).
3. Rest the opener on a support above the top edge of the door to allow for a 25mm gap between the shuttle and the door.
4. Mark the position of the bracket on the wall above the door (**Fig. 05**).
5. Secure the bracket in place with loxins or appropriate fasteners.
6. Secure the opener to the ceiling above drive unit mounting holes, with perforated angle or similar (not supplied). Do not lock the screws at this stage.
7. The door bracket comes in two parts. The top plate is placed over the bottom plate and uses 4 mounting holes for extra strength. Mount the door bracket to the centre line of the door (**Fig. 06**), using M6 or equivalent screws (not supplied) Alternatively it can be welded on steel doors.

NOTE: If in doubt about the strength of the door, reinforcement may need to be added to the frame or panel where necessary. Damage to the door panel may occur if the bracket is installed incorrectly on a panel with insufficient strength. The door opener warranty does not cover damage caused by the opener to the door and/or door panel.

8. Assemble the bent and straight arms with screws, plain and spring washer and nuts supplied in the accessory pack (**Fig. 07**).
9. Connect the assembled arm to the door bracket and the trolley by clevis pin and spring clip.

NOTE: The shuttle must be in disengage position. Always use both the bent & straight arms. If installing on a door with bad wave action, lengthening the arm even further will assist the door operation by reducing the wave action.

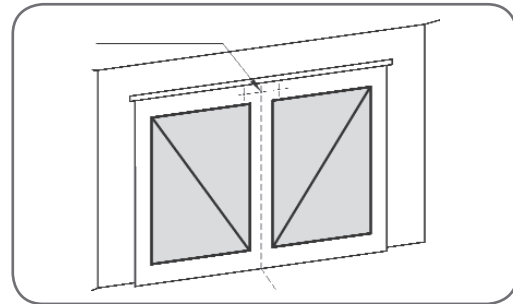

fig 03

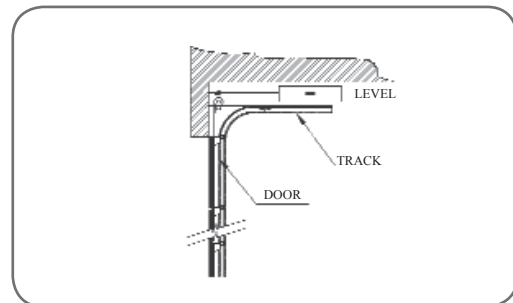

fig 04

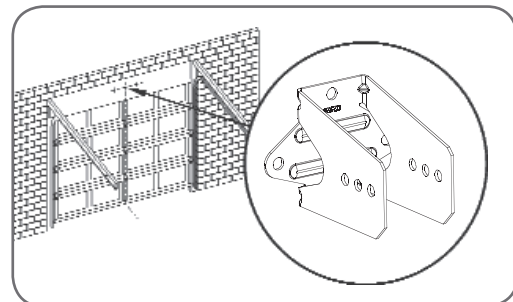

fig 05

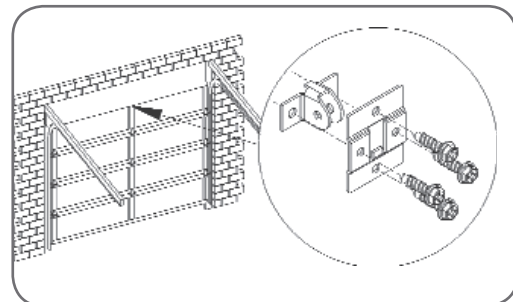

fig 06

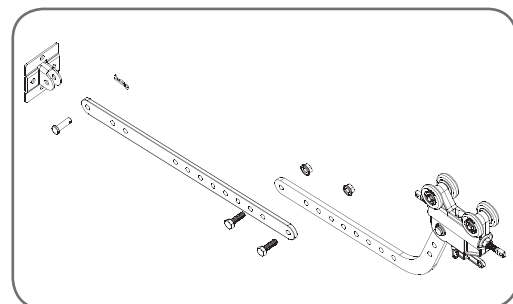

fig 07





Control Board Layout

- 01 02 24VDC output for powering accessories 3A(max)
- 03 Drive unit connections
- 04 Com Terminal for light or lock interface relay drive
- 05 Light interface relay drive
- 06 Lock interface relay drive
- 07 V+ PE Beam power
- 08 PE Input Terminal
- 09 V- PE Beam Power
- 10 COM terminal for inputs terminals 11-16
- 11 OPN N/O input terminal
- 12 STP N/O input terminal
- 13 CLS N/O input terminal
- 14 OSC N/O input terminal
- 15 SWP N/O input terminal
- 16 PED N/O input terminal
- 17 Console Exit Button
- 18 Console Previous Button
- 19 Console Down/Close Button
- 20 Console Up/Open Button
- 21 Console SET Button
- 22 Console Next Button
- 23 Antenna Connector
- 24 Console Display
- 25 Motor Speed Control Connector
- 26 Programmer Interface Connector
- 27 3 Ampere 240 Volt Fuse
- 28 Motor Control Connector
- 29 24V AC Power Supply Input Terminal



Control Board Layout

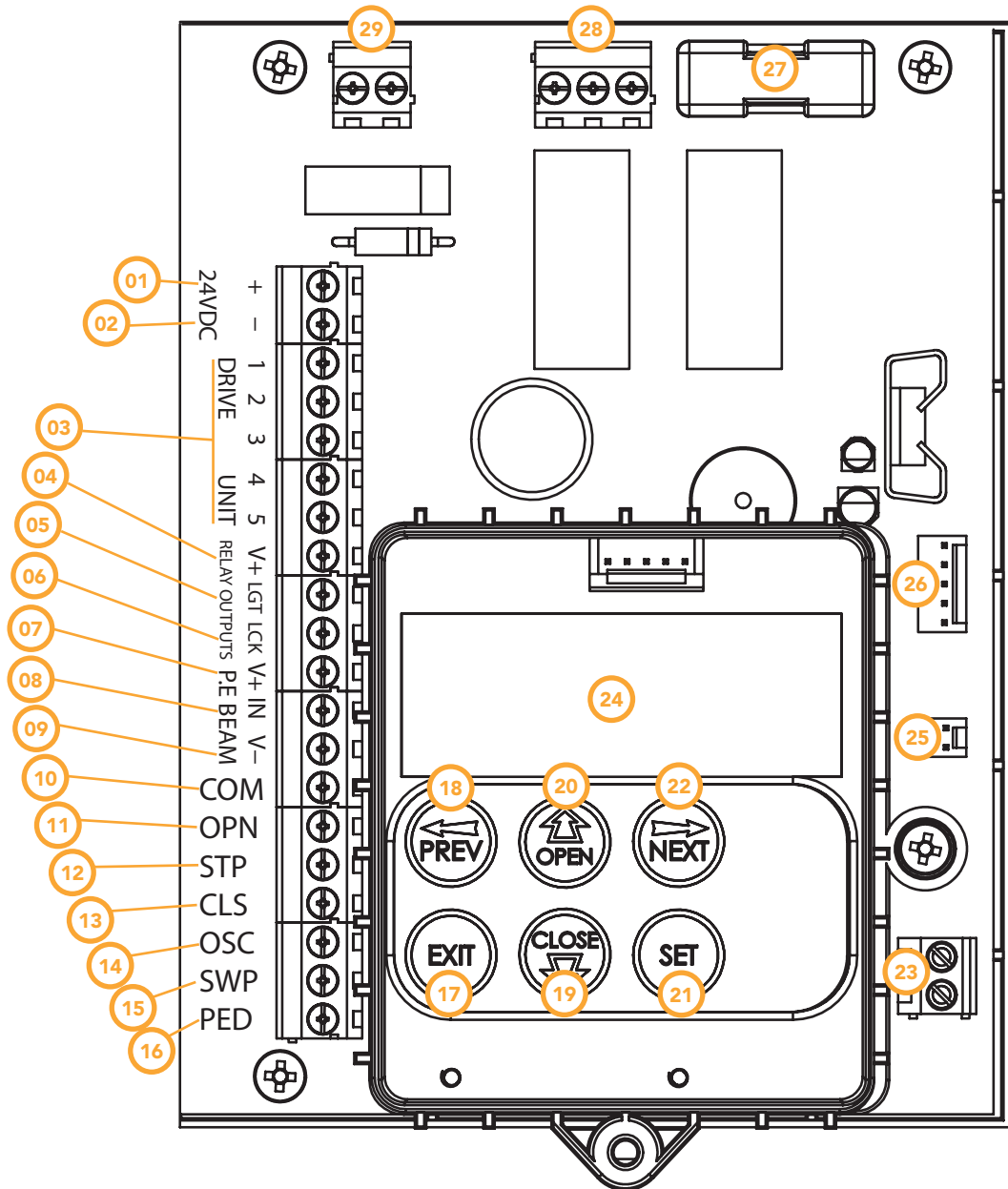

fig 08





Wiring Diagram

fig 09

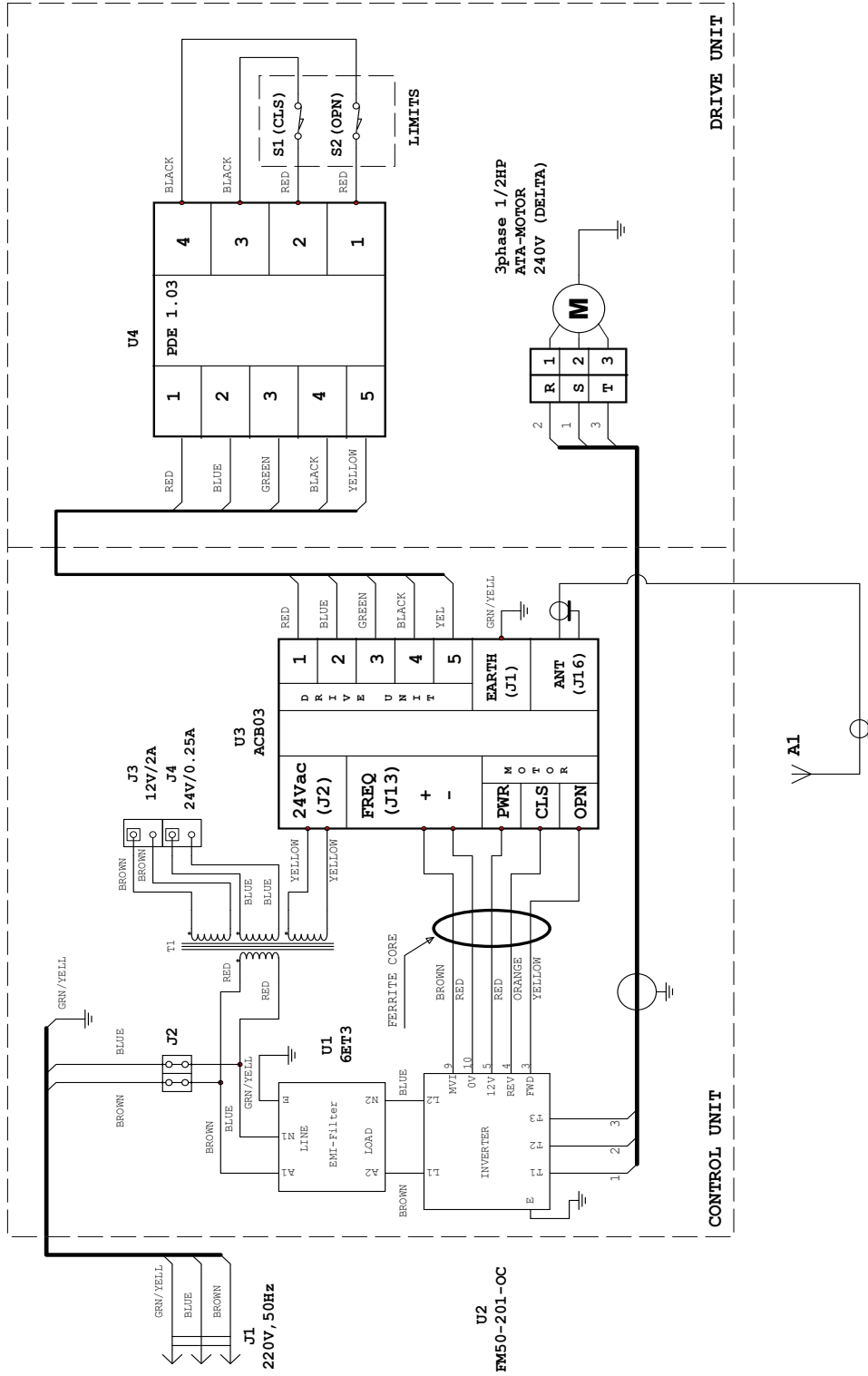



Setting Travel Limits



CAUTION: Cables which have a Green/Yellow coloured insulation are for earthing purposes only. Never use these cables for any other purpose.

This section shows how to set the travel limits. The procedure can be partly completed using a transmitter. In order to use a transmitter, it must first have at least one of its buttons coded to the controller. The function assigned to the transmitter's buttons is of no concern here as the buttons are temporarily assigned to OPEN, CLOSE and SET.

NOTE: The limit setting procedure can be aborted at anytime by pressing EXIT.

Installing Antenna

If the installation requires remote transmitters, an external antenna is required. Mount the antenna as high as possible for optimal reception. Do not cut the coaxial cable.

Powering up

Connect to power. The controller will go through a startup sequence displaying the STARTUP SCREEN which indicates the controller type and firmware version (Fig. 10).

After a short delay, the MAIN SCREEN will be displayed. If this is the first time the controller has been used, the MAIN SCREEN should indicate that the limits are not set. If the display shows that an input is active, rectify the situation before continuing with the procedure for setting the travel limits for the door (Fig. 11).

NOTE: Door should be moved manually to the half open position.

Step 1. Navigating to "Set Door Travel" Menu

1. Press PREV to navigate to the Menu 10.
2. Press SET to display MENU 10.1 (Fig. 12).
3. Press SET again to enter the limit setting procedure (Fig. 13).

Step 2. Selecting The Axess® Model Number

By selecting the model number, the controller will be loaded with the correct settings for motor encoder and speed ramping

1. Press OPEN or CLOSE until "Select Axess® MODEL 1101" is displayed (Fig. 14).
2. Press SET to continue

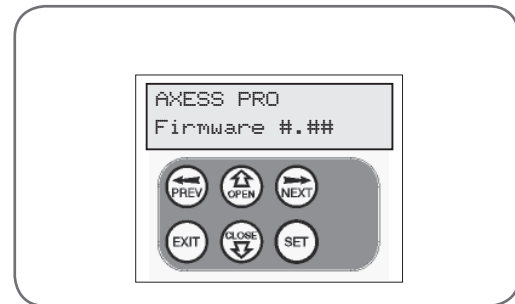

fig 10

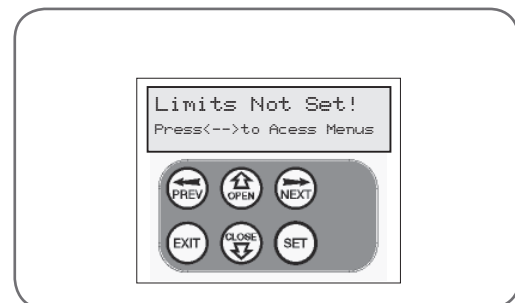

fig 11



fig 12

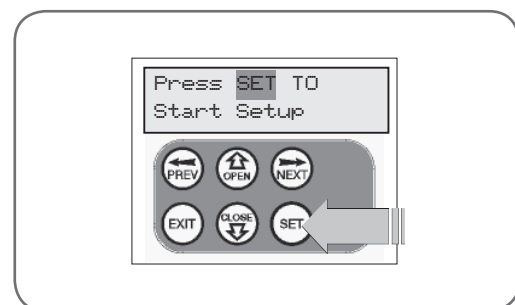

fig 13

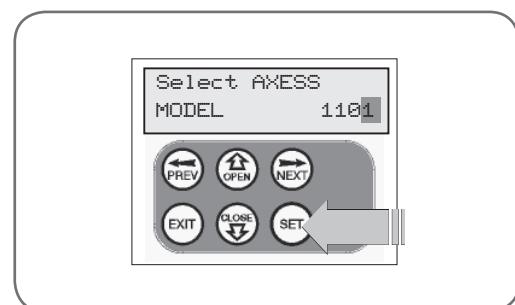

fig 14





Setting Travel Limits

fig 15

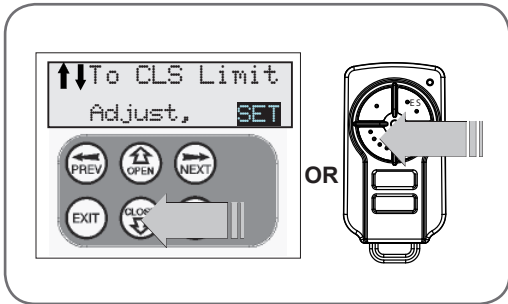

Step 3. Setting Close Travel Limit

1. Press CLOSE to move the door to the desired CLOSE LIMIT. (Or Press button 4 on transmitter) (Fig. 15).
2. Rotate the red CLOSE limit cam until the switch is activated (Fig. 16).

NOTE: If the limit cam engages before the door reaches the required position, adjust the cam back to allow for additional door travel.

3. Press SET to record the CLOSE LIMIT. (Or press button 2 on Transmitter).

NOTE: Limit will not be accepted unless the door is driven in the close direction.

fig 16

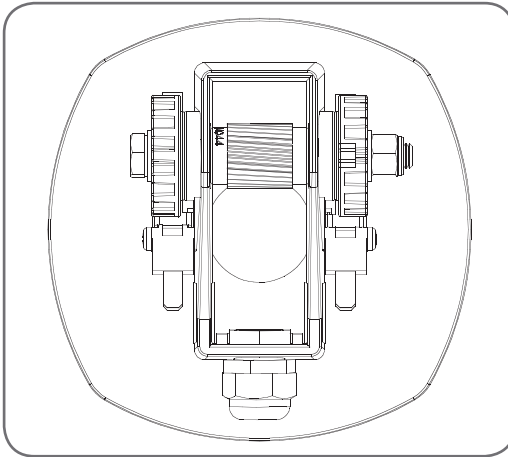

Step 4. Setting Open Travel Limit

1. Press OPEN to move the door to the desired OPEN LIMIT. (Or Press button 1 on transmitter) (Fig. 17).
2. Rotate the green OPEN limit cam until the switch is activated.

NOTE: If the limit cam engages before the door reaches the required position, adjust the cam back to allow for additional door travel.

3. Press SET to record the OPEN LIMIT. (Or press button 2 on Transmitter).

NOTE: Limit will not be accepted unless the door is driven in the open direction.

fig 17

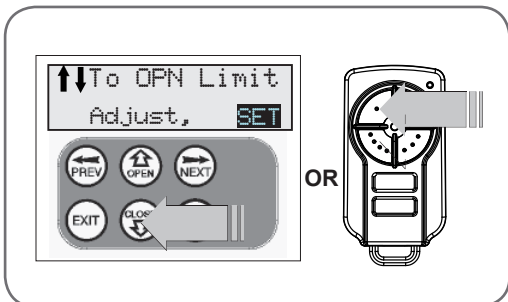

WARNING: If tightening the cam retaining bolt, use two spanners and DO NOT over tighten. It requires no more than a quarter turn of the spanner.

Automatic Limit Adjustment And Load Profile

After a brief pause the controller will automatically close and open the door several times to learn the normal load profile of the door and the normal travel times. When the setup is complete, the MAIN SCREEN will be displayed with the door shown to be closed. The door can now be used.

NOTE: Do not press transmitter during the limit adjustment process.

Errors During Setting Of Travel Limit

During the above procedure many error checks are preformed. If an error is detected, a message will be displayed indicating the error.





Setting Pedestrian Position

Pedestrian Access Position

After completing the travel limit set procedure, the Pedestrian Access Position is automatically set to a position which is in the middle of the door travel. The position can be manually set by following the SETTING PEDESTRIAN POSITION procedure below.

NOTE: Before setting the Pedestrian Access Position, the door must be in the fully closed position. As with the Setting Travel Limit procedure, a transmitter can be used to complete the pedestrian position setting procedure.

Step 1. Navigating to "Set Pedestrian Menu"

1. Press PREV to navigate to Menu 10.
2. Press SET - MENU 10.1 is displayed.
3. Press NEXT to go to MENU 10.2.
4. Press SET to enter Set Pedestrian procedure (Fig. 18).

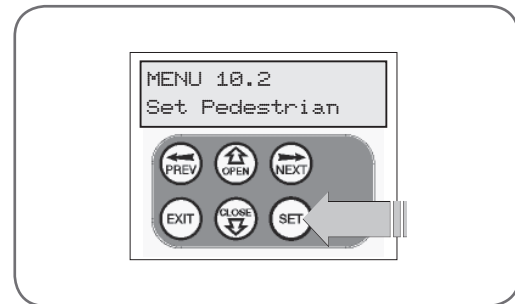

fig 18

Step 2. Setting Pedestrian Position

1. Press OPEN to move the door to the desired pedestrian access position. (Or press button 1 on transmitter) (Fig. 19).
2. Press SET to record position. (Or press button 2 on transmitter).

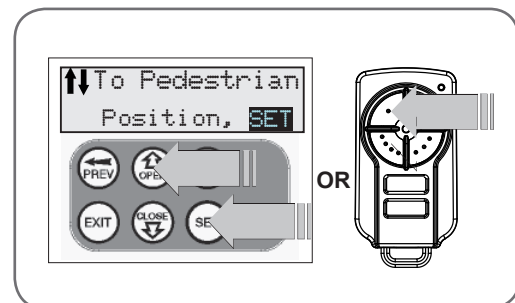

fig 19

Step 3. Pedestrian Position Set

The controller will return to the MAIN SCREEN with the door status shown as being in pedestrian access mode (Fig. 20).

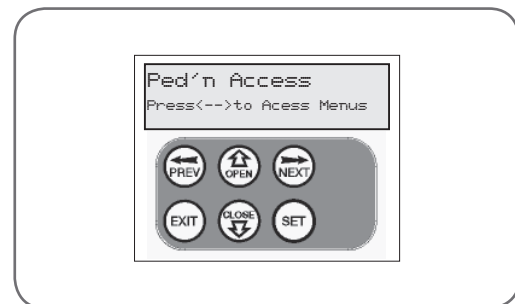

fig 20

Setting Operating Speed

The variable frequency inverter converts 240V single phase power into three phase to run the drive motor. The other main function is to control the soft start/soft stop (accelerate/decelerate) speed. The table below indicates the factory preset and the range.

To change the accelerate/decelerate speed.

1. Press DSP/FUN button to display F06. (Fig. 21)
2. Press DATA/ENT to enter modify mode. Display should show factory default - 50Hz.
3. Press ▲ or ▼ to increase or decrease the frequency .
4. Press DATA/ENT to set.

Function	FN	Unit	Range	Default
Accel./ Decel. Speed	6	0.1Hz	30-70Hz	50Hz



fig 21





Description Of Standard Operation

This section describes the standard operation of the control board with the factory set default values.

Motor Control

The controller drives the motor in the appropriate direction as instructed by the control inputs. Once a cycle is started the motor will continue to travel until:

1. The controller is instructed to stop by a control input.
2. The motor's travel limit is reached.
3. A motor is obstructed, overloaded or stalls.

When the control inputs instruct the control board to change the motor direction, the controller turns off the motor, waits for the motor to stop and then starts the motor in the other direction.

Motor Obstruction Detection

This feature is only enabled if an encoder is fitted to the opener and the encoder option is selected during the travel limit setup.

If a motor is obstructed while opening, the motor is stopped. If a motor is obstructed while closing, the motor is stopped and then reversed to the open position. Obstruction detection is achieved by monitoring the motor's speed and comparing it to the "normal" speed profile. If the speed of the motor falls below the "normal" MARGIN RPM setting, then the motor is said to be obstructed. In addition to the normal motor obstruction detection, motor overload, stall detection and excessive travel time detection is provided to protect the door and opener.

Motor Speed Control (VFD is required)

The motor's speed is controlled using a frequency output connected to a VFD or inverter. When a motor is started, its speed is ramped up to the selected open/close speed % parameter and then ramped down as the travel limit is approached so as to come to a gentle stop.

Lock Release Output

The lock can be installed to the door and connected via the addition of a light relay module which connects across V+ and LCK terminals on the control board. The lock release output is configured to pulse for 0.5 seconds at the start of each cycle. The output is turned on at the same time the motor is started.

Courtesy Light

With the addition of a light relay module which connects across V+ and LGT terminals on the control board, the control board will control a courtesy light. The light is normally used to illuminate the driveway etc. The light will be turned on each time the door is activated (day or night) and automatically turned off 1 minute after the drive cycle has finished. The light can also be activated and deactivated by pressing a transmitter button assigned to the LGT function.

Open/Stop/Close (OSC) Input

(Activated by OSC terminal with N/O switch or by transmitter button with OSC function assigned)

If the door is stopped, the OSC input will cause the door to move in the opposite direction to that last travelled. If the door is moving, the OSC input will cause the door to stop.

Pedestrian Access (PED) Function

(Activated by PED terminal with N/O switch or by transmitter button with PED Function assigned).

The pedestrian access operation partly opens the door, allowing pedestrian access but preventing vehicle access. The position the door is driven to is automatically set to halfway during setting of the travel limits, but can be manually adjusted. Pedestrian access mode is entered when the input is activated and the door is in the closed position. If the door is not in the pedestrian access mode, the PED input will stop the door if moving, or close the door, if stopped. While in pedestrian access mode, the pedestrian access position temporarily becomes the open limit for the door. The PED input then acts with an OSC type function. The pedestrian access mode is exited when the door is closed or when another input is activated.

Close (CLS) Input

(Activated by CLS terminal with N/O switch, by transmitter button with CLS function assigned or by console's CLOSE button). Activating the CLS input will cause the door to close. Holding the input active will prevent opening.

Swipe (SWP) Input

(Activated by SWP terminal with N/O switch or by transmitter button with SWP function assigned). Activating the SWP input will cause the door to be opened. If the terminal input is held, it will prevent the door being closed. The swipe input also effects P.E TRIGGERED AUTO-CLOSE.





Open (OPN) Input

(Activated by OPN terminal with N/O switch, by transmitter button with OPN function assigned or by console's OPEN button). Activating the OPN input will cause the door to open. Holding the input will prevent closing.

NOTE: To activate open input by using N/C switch, change OPN I/P N/C Operation to ON (menu 7.9).

Stop (STP) Input

(Activated by STP terminal with N/O switch, by transmitter button with STP function assigned or by console's EXIT button). Activating the STP input while the door is moving will cause the door to be stopped. If the STP terminal is held it will prevent the door from being moved.

NOTE: To activate stop input by using N/C switch, change STP I/P N/C Operation to ON (menu 7.10).

Photoelectric Safety Beam (P.E) Input

(Activated by PE terminal with N/C switch) When the P.E input is active, the door is prevented from being closed. If the P.E input is triggered while the door is closing, the controller will stop the motors and then open the door. The P.E input has no effect while the door is opening.

Vacation Mode

The controller supports a vacation mode where remote control access is disabled. The mode is activated by pressing a transmitter button with the VAC function assigned until the console displays that vacation mode is enabled (approx. 5 seconds). When activated any transmitter button which is assigned VAC will be ignored. To turn the Vacation mode off simple press a transmitter button with the VAC function assigned (Only requires a brief activation.) Vacation mode can also be turned on or off manually by editing the VACATION MODE parameter.

Parameter Viewing And Editing

This section illustrates how to locate, view and adjust parameters.

Locating Parameters

Refer to MENU STRUCTURE on Page 18 or the preceding section for CONTROL BOARD ADJUSTMENTS. Locate the required parameter and note the MENU number. "AFTER CYCLE LIGHT TIME" (Fig. 22) will be used as an example.

Changing Setting

1. Press NEXT/PREV to navigate to the required menu.
2. Press SET to show sub menu.
3. Press NEXT/PREV to go to the required sub menu.
4. Press SET to enter edit mode (Fig. 23).
5. Press UP/DOWN to change the parameter setting. Holding the button down causes the parameter's value to change rapidly. The longer the button is held the faster the value changes.
6. Press SET to SAVE setting.

Reload Default Setting

1. Press NEXT/PREV buttons to display LOAD DEFAULT screen.
2. Press SET to load the default value.

Return To Menu

If the parameter's value is not to be changed, press EXIT to return to the sub menu. Press EXIT again to return to the MAIN SCREEN.

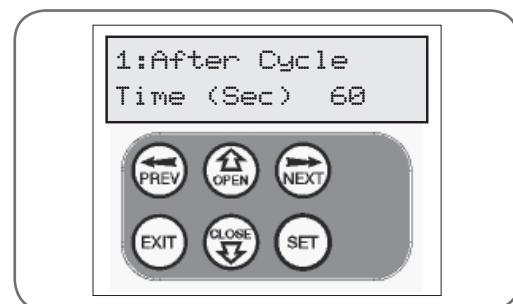

fig 22

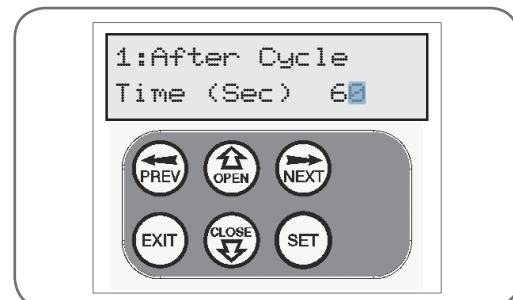
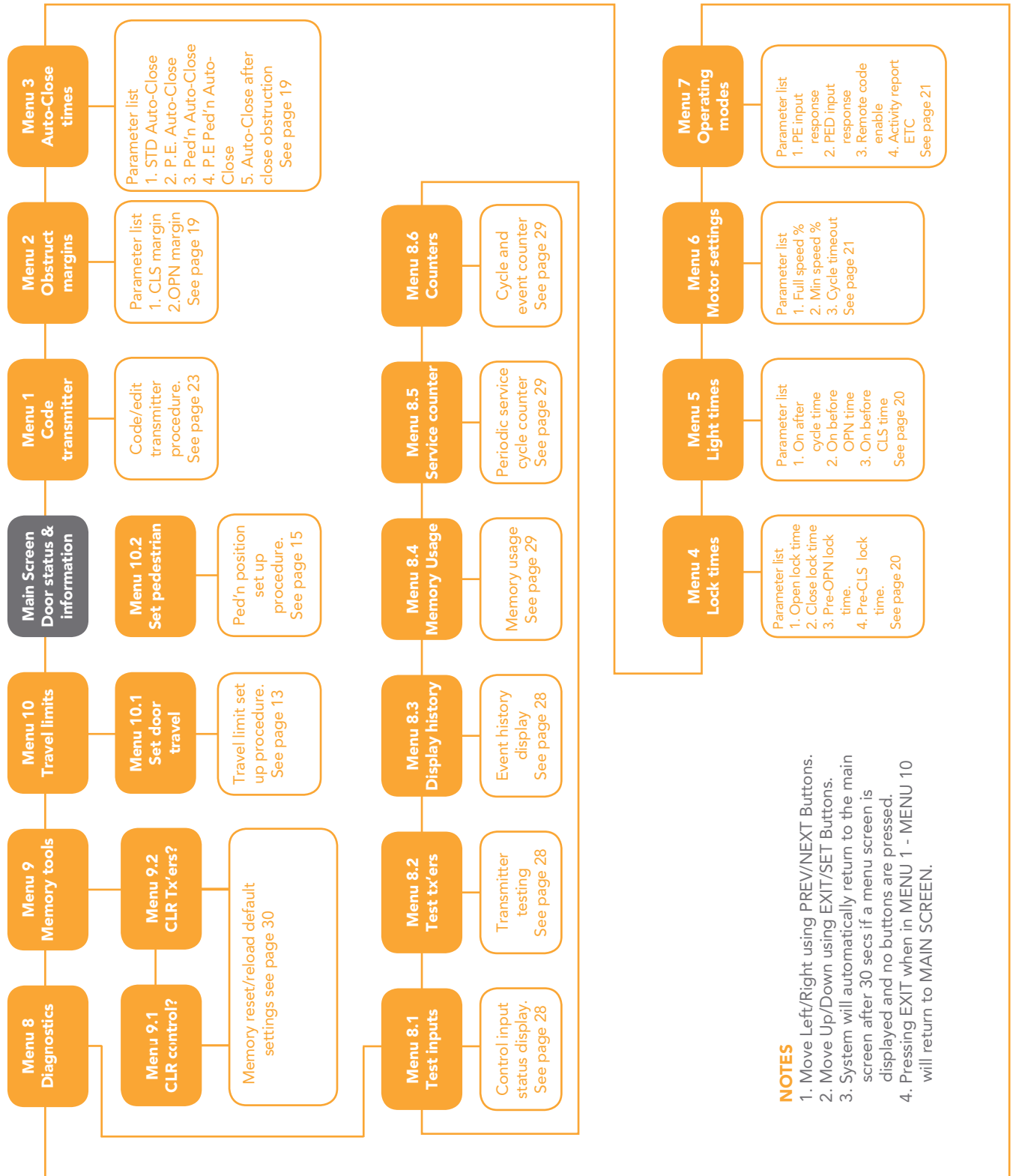

fig 23





Menu Structure



NOTES

1. Move Left/Right using PREV/NEXT Buttons.
2. Move Up/Down using EXIT/SET Buttons.
3. System will automatically return to the main screen after 30 secs if a menu screen is displayed and no buttons are pressed.
4. Pressing EXIT when in MENU 1 - MENU 10 will return to MAIN SCREEN.





Control Board Adjustments

The opener's standard operation can be altered by editing various parameters. This section describes the parameters and the effect they have. Use the VIEWING AND EDITING PARAMETER PROCEDURE on Page 17 to make changes.

Menu 2. Obstruction Margins

The obstruction margins are used to alter the sensitivity of the controller to obstructions. Increasing the value increases the allowable variation between the "normal" force profile and the actual force.

Parameter	Min	Max	Default	Step	Unit	Menu No.
CLS MARGIN Sets the obstruction detection margin for close cycles	0.0	250	100	10	-	2.1
OPN MARGIN Sets the obstruction detection margin for open cycles	0.0	250	100	10	-	2.2

Menu 3. Auto-Close Times

The Auto-Close modes automatically close the door after it has been operated. To implement this, the controller starts a timer once the door has reached its desired open position. The timer then counts down and when it expires, the controller starts to close the door. Details about the four Auto-Close modes follow. Automatic Technology strongly recommend using a PE Beam for added safety.

Standard Auto-Close

This mode is selected by entering a non-zero time for the **STD Auto-Close** parameter. When selected the door will Auto-Close after being fully opened (except when the door has reversed to the open position after a motor obstruction or overload). Countdown is suspended by: the P.E, OPN or SWP input being active. The countdown is aborted if the STP input is activated. If the door is already open and the OPN or the SWP input is activated, then the countdown will start.

P.E triggered Auto-Close

This mode is selected by entering a non-zero time for the **"P.E Auto-Close"** parameter. This mode is used to Auto-Close the door but only after a vehicle has passed through the doorway and triggered the P.E input. The swipe input can be used to clear the P.E

triggered status so that the P.E input must be activated again before the countdown will start. As with the other P.E modes the STP input will abort countdown and the OPN and SWP inputs will restart the countdown if the door is OPEN.

Pedestrian access Auto-Close

This mode is selected by entering a non-zero time for the **"Ped'n A/C"** parameter. When selected the door will Auto-Close after being opened for pedestrian access unless it was following a reverse from an obstruction.

P.E triggered pedestrian Auto-Close

This mode is selected by entering a non-zero time for the **"P.E Ped'n A/C"** parameter. This mode is the same as the P.E triggered Auto-Close mode but it only operates during pedestrian access. As the SWP input is not available during pedestrian access, the PED input can be configured to act in a SWP mode by setting the **"PED I/P = PED SWIPE MODE"** parameter to **ON**.

Auto-Close after obstruction

Two parameters are provided to enable the Auto-Close feature to be activated after obstructions. Normally the Auto-Close feature is not enabled after obstructions for safety reasons. A P.E beam must be used for these features to be activated.

Parameter	Min	Max	Default	Step	Unit	Menu No.
STD AUTO-CLOSE TIME Sets and enables the standard Auto-Close time.	0.0	300.0	0.0	1.0	Sec	3
P.E AUTO-CLOSE TIME Sets and enables the P.E triggered Auto-Close time.	0.0	60.0	0.0	1.0	Sec	3
PEDESTRIAN AUTO-CLOSE TIME Sets and enables the Pedestrian Auto-Close time.	0.0	60.0	0.0	1.0	Sec	3
P.E PEDESTRIAN AUTO-CLOSE TIME Sets and enables the PE Pedestrian Auto-Close time.	0.0	60.0	0.0	1.0	Sec	3
AUTO-CLOSE AFTER CLOSE OBSTRUCTION Enables Auto-Close feature after close obstructions	Off	On	Off			3
AUTO-CLOSE AFTER OPEN OBSTRUCTION Enables Auto-Close feature after open obstructions	Off	On	Off			3



Control Board Adjustments

Menu 4. Lock Times

With the addition of a relay module connected to the control board, the electric lock can be controlled. Lock output can be programmed for both hold and pulse operation and can also be programmed to activate prior to the door motor starting. The operation of the lock can be programmed to behave differently on open cycles to that on close cycles.

Parameter	Min	Max	Default	Step	Unit	Menu No.
OPEN LOCK TIME Set the time the lock is activated for on open cycles	0.0	Hold	0.5	0.1	Sec	4
CLOSE LOCK TIME Set the time the lock is activated for on close cycles	0.0	Hold	0.5	0.1	Sec	4
PRE-OPEN LOCK TIME Time the lock is activated for prior to opening	0.0	25.5	0.0	0.1	Sec	4
PRE-CLOSE LOCK TIME Time the lock is activated for prior to closing	0.0	25.5	0.0	0.1	Sec	4

Menu 5. Light Times

With the addition of a relay module connected to the control board, a light can be controlled. The time the light stays on is controlled by two timers. The first times the length of time the light is activated for prior to a drive cycle. This is used to warn that door movement is pending. The second times how long the light remains on after a cycle. The parameters are shown below.

Parameter	Min	Max	Default	Step	Unit	Menu No.
ON AFTER CYCLE LIGHT TIME Time light remains on for after a cycle	0	255	60	1	Sec	5
ON BEFORE OPEN CYCLE LIGHT TIME Minimum time light is activated for prior to opening	0	25.5	0	0.1	Sec	5
ON BEFORE CLOSE CYCLE LIGHT TIME Minimum time light is activated for prior to closing	0	25.5	0	0.1	Sec	5





Menu 6. Motor Settings

Motor Speeds

When speed ramping is enabled during the limit setup procedure, the controller will ramp the motor speed up at a start of the cycle and then down again at the end of the cycle prior to stopping at the limit. The parameters for open and close speeds set the respective motor speed for the open and close cycles. The minimum speed parameter sets the minimum speed output to the motor at the start and end of ramping.

NOTE: Altering these parameters will cause the travel limits to be cleared.

Cycle Timeout

Sets the maximum time a cycle can run past its normal cycle time for before an obstruction is tripped.

Parameter	Min	Max	Default	Step	Unit	Menu No.
CLOSE SPEED Sets the motor speed for close cycles	1	100	100	1	%	6.1
OPEN SPEED Sets the motor speed for open cycles	1	100	100	1	%	6.2
MIN SPEED Minimum speed output to the motor	1	100	40	1	%	6.3
CYCLE TIMEOUT (NORM +) Cycle overrun time permitted before obstruction	0.1	25.5	2.0	0.1	Sec	6.4
ACC SLOPE Sets the motor acceleration time	10	2500	50	10	%/Sec	6.5
SLOW SLOPE Sets the motor deceleration time	0	1.5	0.3	0.1	%/Count	6.6
STOP TIME Sets the time given to motor to bring to rest	0.1	1.00	0.5	0.1	Sec	6.7

Menu 7. Operating modes

P.E input response mode

The P.E input can be configured to respond in one of three modes.

Open and close cycles stop

In this mode, all cycles are prevented from being completed or initiated when the P.E input is active.

Close cycles stop

In this mode, the P.E input has no effect when opening but will stop the door when closing.

Reverses close cycles

In this mode, the P.E input has no effect when opening but will cause the door to reverse if activated when closing.

Ped input function

The PED input can be configured to a SWIPE type input for pedestrian access. This provides full functionality with the P.E Triggered Pedestrian Auto-Close function.

Remote code

The controller supports the Remote Code Set feature. This parameter can be used to disable the feature for security or transmitter management reasons.

Activity reports

This parameter enables activity report outputs. Contact Automatic Technology for more details.





Activity report ID

This parameter sets the ID of the controller that is sent with the activity report. Contact Automatic Technology for more details.

Vacation mode

Vacation mode can be turned on or off using this parameter.

Password protection

The password feature enables all parameters and configuration settings to be protected unless a password is entered. When this feature is turned on the user is requested to enter the desired password to be used. The password protection feature has a time-out that expires after 60 seconds of inactivity. Alternatively the user may log out manually by pressing exit when the main screen is displayed.

Transmitter grouping

The transmitter store number display format can be changed to show a grouped format. When grouping is selected, instead of displaying the store location as a number between 1 and 511, it is displayed as ##\$ where ## is the group number and \$ is a character a,b,c,d,e,f,g or h which indicates the group member.

Open input polarity

The OPN input is normally configured for N/O operation. This parameter allows its operation to be changed to N/C.

Stop input polarity

The STP input is normally configured for N/O operation. This parameter allows its operation to be changed to N/C.

Open input as second PE BEAM input

The open input can be configured to use as a second normally open PE beam input.

Parameter	Min	Max	Default	Step	Unit	Menu No.
P.E INPUT RESPONSE MODE Sets the P.E response mode. Options are OPEN and CLOSE cycles stop, Close cycles stop or Close cycle reverse			CLS to reverse			7.1
PED INPUT = SWIPE MODE Selects PED input functions as pedestrian access swipe input	Off	On	Off			7.2
REMOTE CODE ENABLED Selects remote transmitter coding function	Off	On	Off			7.3
ACTIVITY REPORTS Select report to be output	Off	255	Off	1		7.4
ACTIVITY REPORT ID Selects ID for controller, sent with activity report	0	65535	0	1		7.5
VACATION MODE Selects vacation mode - disables remote control	Off	On	Off			7.6
PASSWORD Selects password protection for all changes	Off	On	Off			7.7
TX # GROUPING Selects tx'er number group display format	Off	On	Off			7.8
OPN INPUT N/C OPERATION Selects operating polarity of OPN input	Off	On	Off			7.9
STP INPUT N/C OPERATION Selects operating polarity of STP input	Off	On	Off			7.10
OPN INPUT 2nd P.E OPERATION Selects OPN input as 2nd P.E input	Off	On	Off			7.11





Coding Transmitter

Up to 511 transmitters can be stored within the opener's memory. Each transmitter can be allocated an alpha-numeric ID label up to eleven (11) characters in length and each button can be assigned to one of several control functions. The settings for a transmitter are represented in (Fig. 24). It shows the transmitter's store number, ID label or Serial number and the functions assigned to each of its four buttons. To toggle between ID/SN display, press UP/DOWN with the cursor on the ID/SN indicator. The procedures below code, delete, replace, edit and copy transmitter records.

Coding Transmitter Button

STEP1. Navigating To "Code Transmitter" Menu

1. Press NEXT to navigate to Menu 1.
2. Press SET to enter the code set procedure (Fig. 25).

Step 2. Storing Transmitter Code

1. Controller will prompt to press one of the transmitter's buttons.
2. Press the transmitter button you wish to use to operate the door opener (e.g. button 1) (Fig. 26).
3. Press the same transmitter button again as prompted by the display. (Fig. 27).

Step 3. Selecting Function Of The Button

The controller will now show the transmitter's record, with a cursor on the field for the button being coded (Fig. 26). Use UP/DOWN to select the function for the button.

Available functions:

- VAC (Vacation Mode)
- LGT (Courtesy Light)
- STP (Stop)
- OPN (Open)
- CLS (Close)
- SWP (Swipe)
- PED (Pedestrian access)
- OSC (Open/Stop/Close)
- OFF (No action)

Press SET to save the settings or EXIT to abort without saving (Fig. 28).

Returning to main screen

The "Code Transmitter" menu will now be shown. Press EXIT to return to the MAIN SCREEN and test the transmitter.

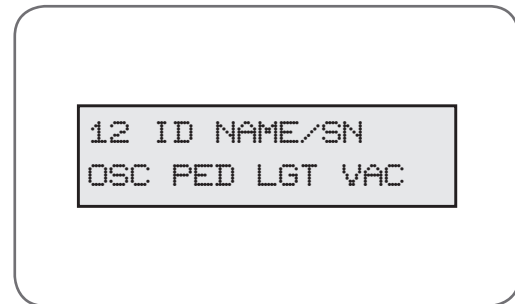

fig 24

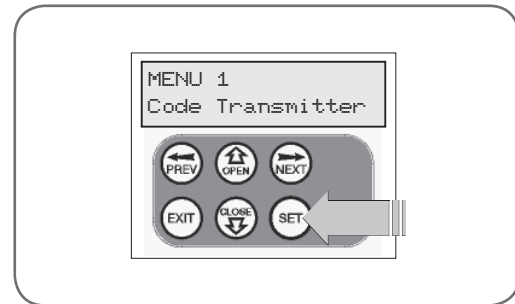

fig 25

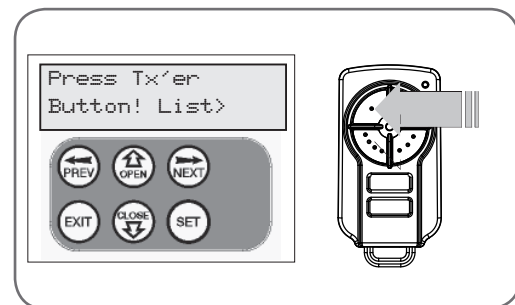

fig 26

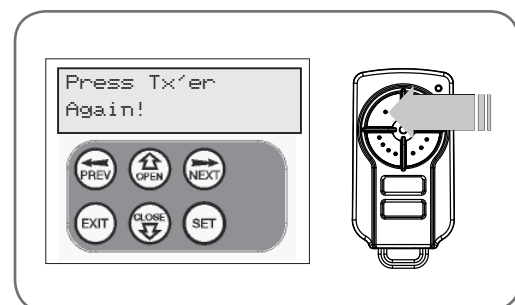

fig 27

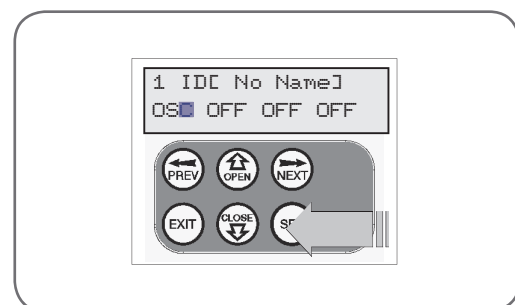

fig 28





Transmitter Edit Procedure

fig 29

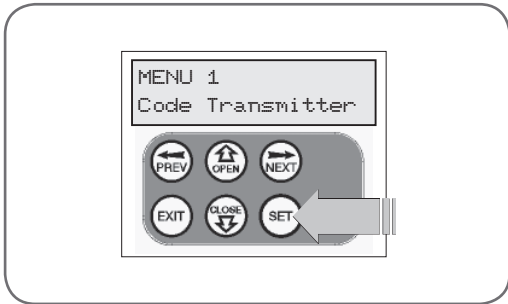

fig 30

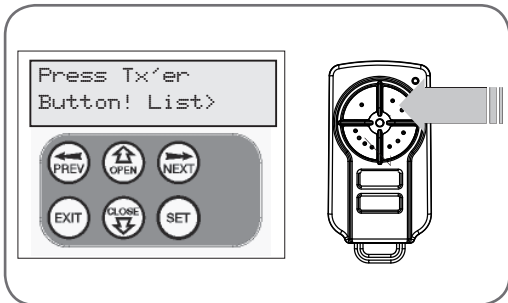

fig 31

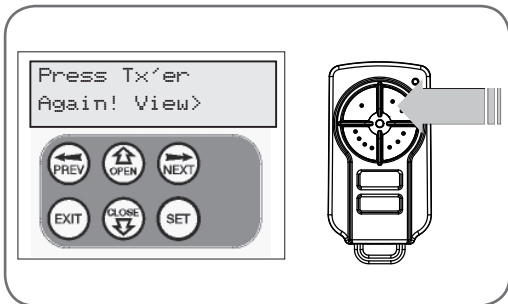
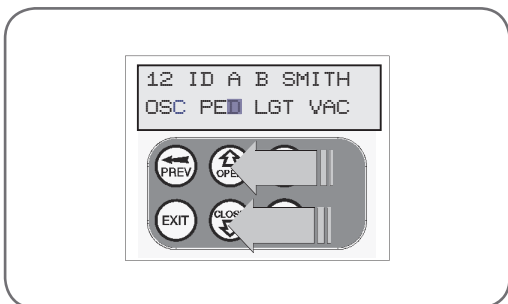

fig 32



Editing Transmitter Settings Display Transmitter Record

Using the method below, the required transmitters details are displayed.

Step 1. Navigating To "Edit Transmitter" Menu

1. Press NEXT to navigate to Menu 1.
2. Press the SET button (Fig. 29). The Controller will prompt to press one of the transmitter's buttons.
3. Press the button of the pre-coded transmitter you wish to edit (e.g. button 2) (Fig. 30).
4. Press the same transmitter button again as prompted by the display. (Fig. 31).

Step 2. Editing Button Function Field

1. Press NEXT or PREV to move the cursor to the left or right and between the top and bottom lines to select the desired field.
2. Press UP or DOWN to change the displayed value (Fig. 32).

The available functions are shown below. Selecting OFF will prevent the opener responding to that button.

Available functions

VAC (Vacation Mode)	LGT (Courtesy Light)
STP (Stop)	OPN (Open)
CLS (Close)	SWP (Swipe)
PED (Pedestrian access)	OSC (Open/Stop/Close)
OFF (No action)	

3. Press SET to save changes or press NEXT or PREV to move to the next field. The example in (Fig. 32) shows that PED is assigned to the transmitter button 2. The transmitter in the example is transmitter number 12 which has the ID label AB Smith.

NOTE: If all button functions are set to OFF, when SET is pressed, the opener will prompt to confirm if the transmitter is to be deleted. Press SET to delete or EXIT to continue editing.

Step 3. Editing The Store Location

This feature is only available when coding the first button of a new transmitter.

1. Press NEXT or PREV to move the cursor over Store No.
2. Press UP or DOWN to select new Store No.
3. Press SET to Confirm or NEXT/PREV to move to the next field.

NOTE: This is useful when managing transmitters using a scheme which ties the store location to the transmitter's





Transmitter Edit Procedure

owner.

Step 4. Selection Of ID or SN Display

1. Press NEXT/PREV to move the cursor over the ID field.
2. Press NEXT to reveal the serial number (**Fig. 33**). The serial number display is provided for additional means of identification. The transmitter in this example has S/N: 12345.

Step 5. Editing a Character Field

1. Press NEXT or PREV to select character to change.
2. Press UP or DOWN to scroll through and select new character (**Fig. 34**).
3. Press NEXT or PREV to move to next character.
4. Repeat step 2.
5. Press SET to record changes. The second line of the display shows a list of available characters with the current value indicated at the cursor position.

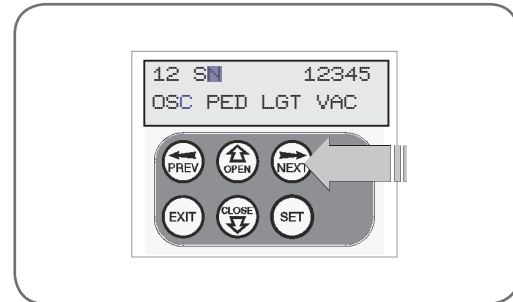

fig 33

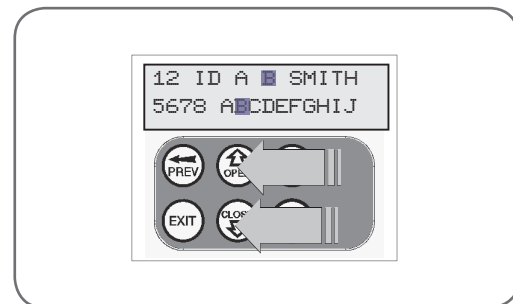

fig 34

Transmitter Management

The opener provides a transmitter listing facility which enables the user to find a transmitter location within memory. Once located, a stored transmitter can be replaced, deleted, edited, copied or, if the location is empty, a new transmitter can be coded.

Step 1 Accessing The List Menu

1. Press NEXT to navigate to Menu 1.
2. Press SET to enter the transmitter edit procedure (**Fig. 35**).
3. Press NEXT to enter the transmitter list and edit mode (**Fig. 36**).

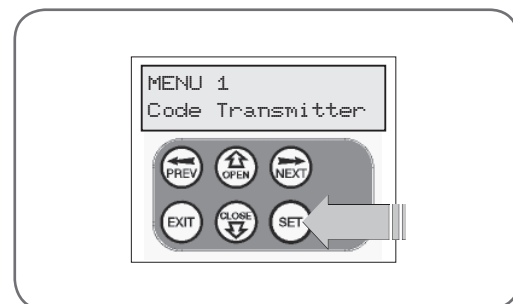

fig 35

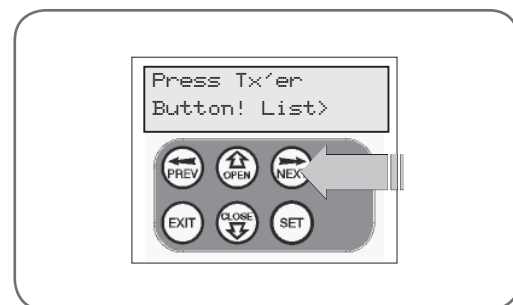

fig 36





Transmitter Management

fig 37

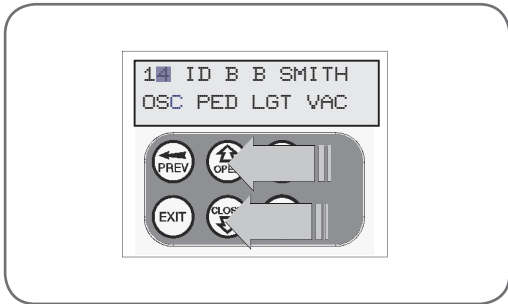

Once the list is displayed it can be sorted by Store number, ID Label or Serial Number. Use the NEXT or PREV buttons to select sorting method.

NOTE: When sorting by ID label or S/N, only stored transmitters locations are displayed.

Step 2. Navigating The List

1. Press UP or DOWN buttons to navigate through list (**Fig. 37**).
2. Press SET to display the menu of available functions.

NOTE: Holding a button down will step through the list faster.

fig 38

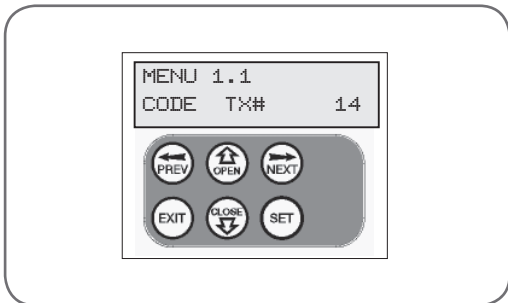

Selecting An Operation

Press NEXT or PREV to cycle through the four menu options (**Fig. 38 - 41**). Press EXIT to return to the list. Press SET to execute the menu's operation.

Code Operation (Location Empty)

If the code operation is selected on an empty transmitter location, the BASIC CODE TRANSMITTER PROCEDURE will be initiated with the transmitter being saved in the selected location. This is useful when managing transmitters using a scheme which ties the store location to the transmitter's owner.

Code Operation (Location Used)

If the code operation is selected for a location that already contains a transmitter, then the BASIC CODE TRANSMITTER PROCEDURE will be initiated and the new transmitter will replace the existing one. Note that the button functions and name of the existing transmitter will be transferred to the new transmitter. This procedure is of great convenience when replacing a lost transmitter.

fig 39

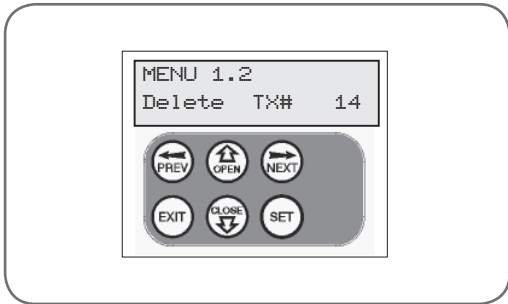

Delete Operation

The delete operation is used to remove a transmitter from memory along with the name and button function settings.

fig 40

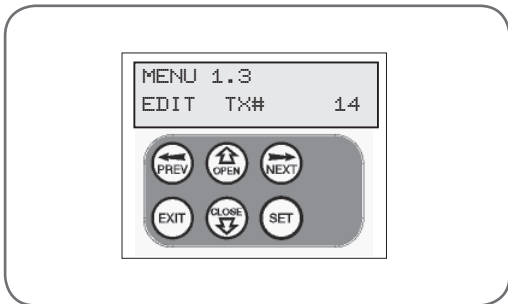

Edit Operation

The edit operation displays the transmitter record for editing purposes. See TRANSMITTER EDIT PROCEDURE for details.

fig 41

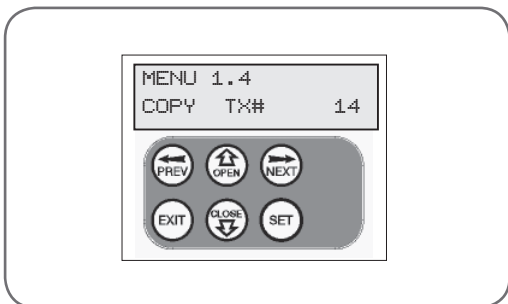

Copy Operation

The copy operation is used to code multiple transmitters with the same button function as that of the selected transmitter. Once selected an abbreviated code set routine is initiated for each transmitter to be coded. Coding is terminated by pressing the EXIT button.

Exiting The List

To exit the transmitter list, simply press EXIT to return to the Code Transmitter Menu.





Remote Code Set Procedure

fig 42

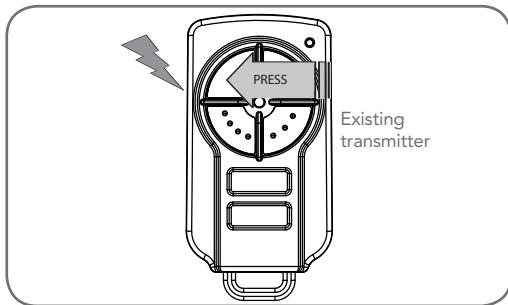

fig 43

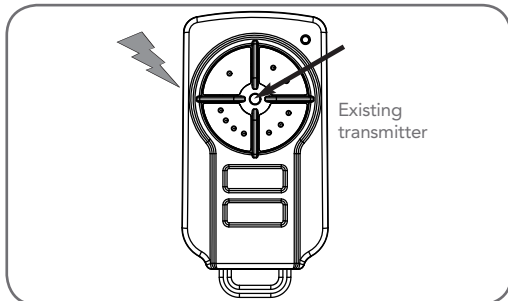
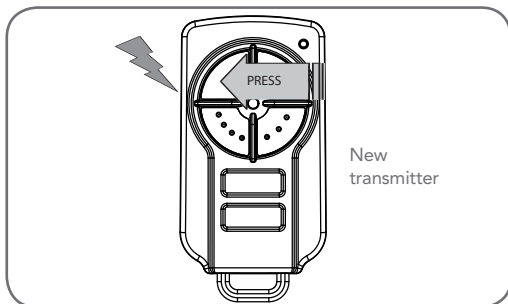

fig 44



If a transmitter is already coded into the opener, additional transmitters can be coded without being in direct contact with the opener's control panel.

NOTE: Only the function of the existing transmitter button can be assigned to a new transmitter. Please read instructions prior to proceeding - there is a time-out facility for security reasons.

Step 1. Selecting The Function To Be Coded

Using the existing transmitter, operate the door with the transmitter button which has the function to be coded (Fig. 42) (e.g. Button 1 has been coded with the OSC function assigned).

Step 2. Wait For Door To Complete Cycle

If the button's function activates the door (PED, SWP, OSC, CLS, STP or OPN) wait for the door to complete its cycle.

Step 3. Activate Remote Code Set Mode

Using a small pin, press and hold through the Coding Hole of the existing transmitter for two seconds (Fig. 43).

Step 4. Code New Transmitter Button

Within 10 seconds, press the button on the new transmitter you wish to code for 2 seconds (Fig. 44).

Step 5. Confirm Transmitter Button To Be Coded

Press the same button again (within 10 seconds) for confirmation.

Step 6. Test Operation

The new transmitter button should now function as the existing transmitter.

NOTE: When a transmitter is remote coded, its ID label is set to that of the existing transmitter. If the existing transmitter does not have an ID label assigned, then the ID label of the new transmitter is set to: R/C Tx ###, where ### is the existing transmitters store number. This ensures that the originator of any remote coded transmitter can be identified.





Diagnostic Tools

fig 45

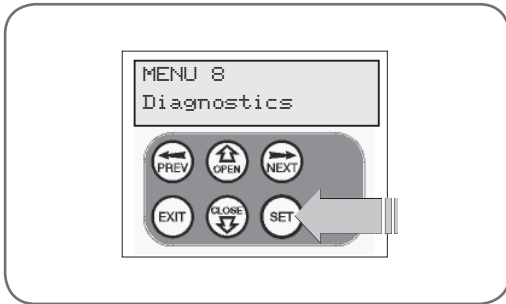

fig 46

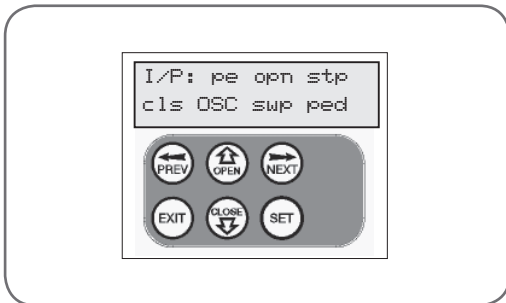
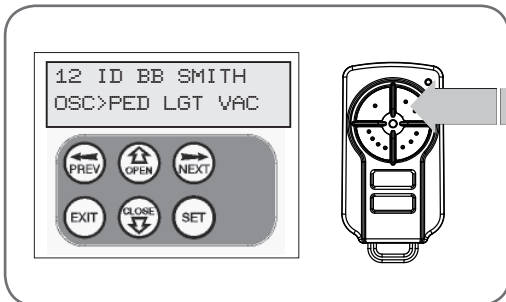

fig 47



fig 48



Menu 8

The controller provides several diagnostic tools from within the diagnostics menu (menu 8). This section details the function of each tool and its use.

Navigating To Diagnostics Menu

1. Press PREV to navigate Menu 8.
2. Press SET to display menu of available functions (**Fig. 45**).
3. Press PREV or NEXT to cycle through the diagnostic tool.
4. Press SET to select.

Menu 8.1 Test Inputs

This tool is used to view the state of the control inputs. When selected, a screen is displayed (**Fig. 46**) which indicates the state of each input. If the name of the input is in uppercase then the input is active, conversely if the input is in lowercase then the input is inactive. For normal operation all inputs should be inactive. When finished press EXIT. The example shows the status as OSC input is active.

Menu 8.2 Test Tx'ers

This tool is used to test receiver/transmitter functionality. When selected, a screen is displayed which prompts for a transmitter button to be pressed (**Fig. 47**) and whether ID or serial numbers are to be displayed.

The opener will then beep each time a transmission is received. If the transmitter button is stored in the controller memory and has a function assigned to it, a second screen will be displayed that shows the transmitter details along with the button pressed (**Fig. 48**). The example shows the case when transmitter number 12 is activated by button 2. Note ID is selected for display.





Diagnostic Tools

Menu 8.3 Display History

The opener keeps a record of the last 64 events that have taken place. The events include the type of drive cycles executed, obstruction detection, various faults, power failures etc. When this tool is selected the screen displays the last event that occurred (Fig. 49). Press NEXT or PREV to view each event. The "EVENT#" field shows the sequence of the events, with (1) being the first and (64) being the last. The example shows that the last event was a close cycle which succeeded in closing the door. When finished viewing the events, press EXIT.



fig 49

Menu 8.4 Memory Usage

This tool displays the number of transmitter store location used and the number free (Fig. 50).

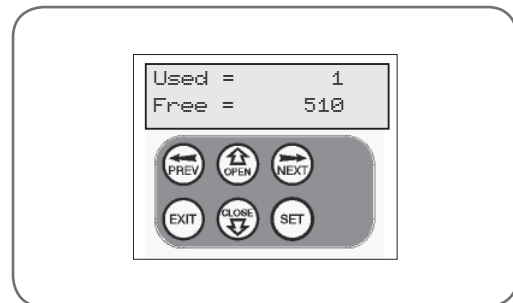

fig 50

Menu 8.5 Service Counter

The opener provides a periodic service counter which can be set to expire after a number of drive cycles. When expired, the opener will beep at the beginning of each drive cycle and a message will be displayed on the MAIN SCREEN. This tool displays the current value of the service counter and allows the user to set its value using the normal parameter editing techniques (See PARAMETER VIEWING AND EDITING). If the service counter is not to be used it can be set to the maximum number (60,000) (Fig. 51)

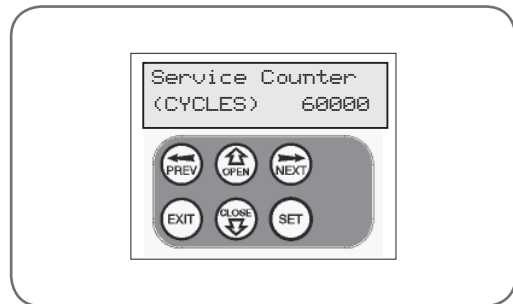

fig 51

Menu 8.6 Counters

The opener keeps a count of number of times a particular event occurs. The list of event counters kept is shown below. When this tool is selected, the first event counter is shown (Fig. 52). Press NEXT or PREV to step through the list. The example below shows the OPEN CYCLE event counter with a value of 1200. When finished viewing press EXIT.

- | | |
|-----------------|-------------------------|
| 1: Open Cycles | 7: Open Obstructions |
| 2: Close Cycles | 8: Close Obstructions |
| 3: Ped Cycles | 9: Open Overloads |
| 4: Setup Limits | 10: Close Overloads |
| 5: Open Stall | 11: Limit Sensor Faults |
| 6: Close Stall | |

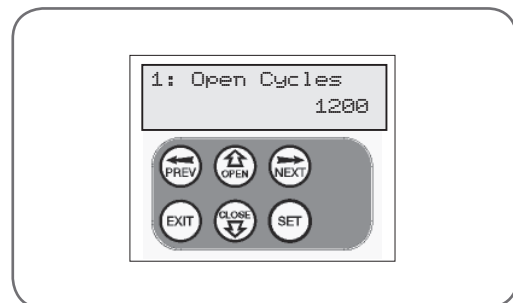

fig 52

Menu 8.7 Installation

The controller keeps a record of the options selected during installation and also the travel times recorded during installation. The list below shows the information recorded. Use the NEXT and PREV buttons to move through the list. When finished viewing simply press EXIT.

- | | |
|---------------------|-----------------------|
| 1: Open Cycle Time | 3: Motor Encoder Mode |
| 2: Close Cycle Time | 4: Speed Ramping Mode |





Memory Tools

fig 53

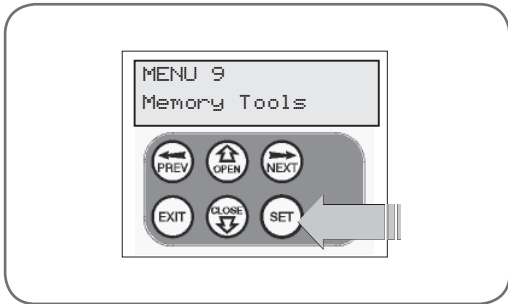

The Memory Tools accessed from within Menu 9 are used to clear the controller's memory. Once selected the PREV or NEXT buttons can be used to view the Memory Tool options. To Execute the displayed option simply press SET (Fig. 53).

Menu 9.1 Clr Control

This option will clear the door control memory and reload the factory set defaults for parameters such as the lock time, light time, Auto-Close times etc. It will also clear the travel limits.

Menu 9.2 Clr Tx'ers

This option will clear the transmitter storage memory.

Accessories Installation

fig 54

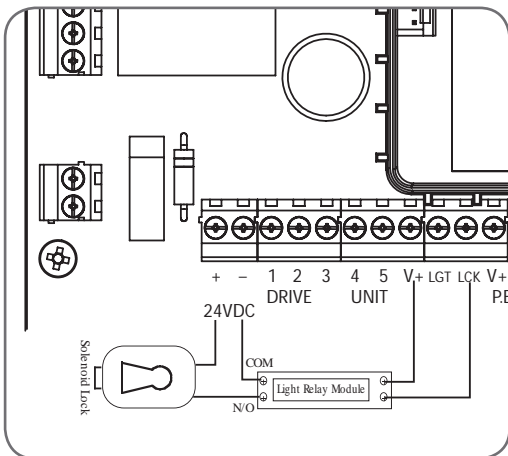

Fitting Solenoid Or Magnetic Lock

Install the lock mechanism on the door as per the manufacturers instructions. The wiring diagram shown in Fig. 54 is a representation of a typical lock with a bias for normally closed contact. See Page 20 for Lock Times set up.

Fitting Courtesy Light

An AC or DC courtesy light can be activated via an output on the control board. Connect the light as shown in (Fig. 55). See Page 20 for Light Times set up.



WARNING: A qualified electrician must perform the installation where 240V AC power is used.

fig 55

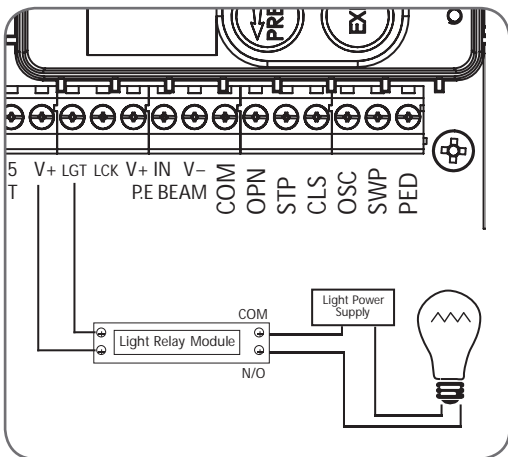



PE Beams Installation instructions

Photo Electric (PE) Beams

A photo electric (PE) Beams extends across the door opening. This photo electric (PE) Beams is designed to detect an obstruction while the door is closing and to send a signal to the door opener to reverse or stop the door movement.

Fitting Photo Electric (PE) Beams

- Attach the mounting bracket (4) to adjustment bracket (3) with the pan head screw (6) (supplied). (Fig. 56)
- Attach the PE 2000TS bracket (2) to PE beam transmitter (IR-200TS-TX) with four tapite screws (m3x5) and attach the other side to adjustment bracket (3) with the pan head screw (6) (supplied).
- Repeat steps a and b to assemble the PE Beam receiver (IR-200TS-RX).

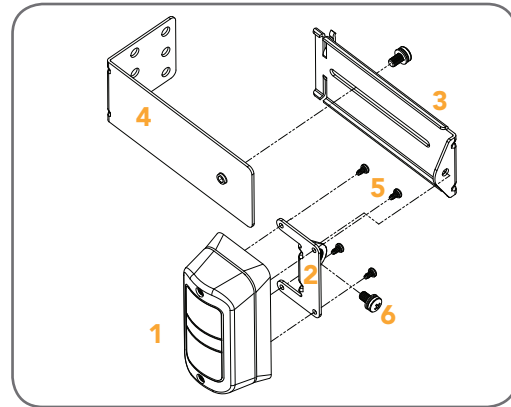

fig 56

Locate the Photo Electric (PE) Beams in a strategic location in the doorway. Automatic Technology recommend that the sensor is placed 100 mm above the floor level and as close as possible to the door opening. Connect as per the wiring diagram (Fig. 58).

Use 5.6 kilo ohm resistor with the colour code green, blue, red and gold on the PE Beams receiver between the V- and NC terminals as shown in (Fig. 58).

Alignment

- Power up the PE Beams. The green LED on the transmitter and red LED on the receiver should turn ON to indicate power is present.
- If the receiver is connected to power and the red LED is on while the green LED is on, the transmitter and receiver are not aligned.
- Make horizontal and/or vertical adjustment on the transmitter and/or receiver until the red LED turns off on the receiver, indicating alignment.

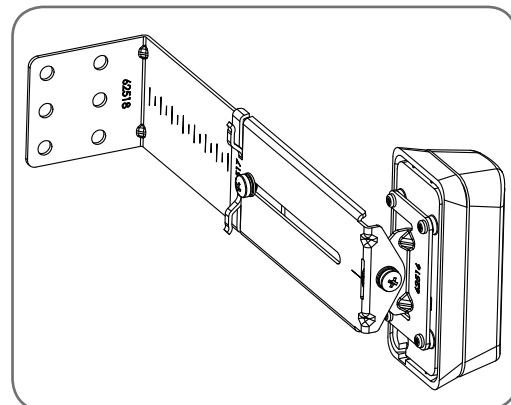

fig 57

NOTE: The height of the beam installation must be chosen in such a manner that it suits the application and environmental conditions and provides maximum safety protection.



WARNING: When using PE Beams, the doorway must be clear of all obstructions and persons at all times. The location of the beams and manner in which it is installed might not give safety protection at all times. Check to make sure that the height of the beam and type used give maximum protection possible.



WARNING: Install the PE Beams as per diagram in (Fig. 58). **Tampering** with the PE Beams could result in serious personal injury and/or property damage and will void the warranty.



WARNING: PE beams must be installed if the closing force at the bottom edge of the door exceeds 400N (40kg force)

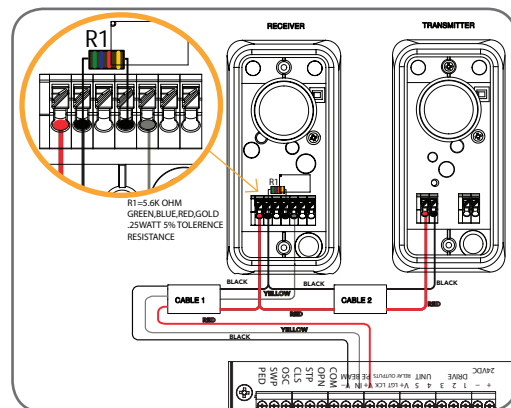

fig 58





Troubleshooting

Possible cause	Possible cause	Remedy
Door will not operate	Mains power not switched on Door is obstructed Door is locked or motor jammed Door tracks/hardware damaged	Switch on mains power Remove obstruction Unlock door or remove jam Door requires service/repair by qualified technician
Door does not operate from transmitter *See note	Transmitter code not stored in memory Flat battery	Code transmitter in to openers memory. Refer page 23 Replace battery - CR2032
Door will not close fully	Door limits positions need to be reset	Reset limits positions. Page 13
Door will not open fully	Door limits positions need to be reset	Reset limits positions. Page 13
Auto-Close not working	PE Beam or wiring faulty PE Beam not aligned correctly PE Beam is obstructed Door obstructed when closing Auto-Close time not set	Repair PE Beam or replace wiring Re-align optics Remove obstruction from path of PE Remove obstruction See page 19

PLEASE NOTE:

Some areas may be prone to excessive radio interference brought on by devices such as cordless telephones, wireless stereo headphones and baby monitors. It is possible that these devices could cause a degree of interference such as to greatly reduce the range of the transmitter. In such an instance please contact your Automatic Technology dealer for assistance. As this is not a warrantable situation but an environmental issue, charges may apply.





System Specifications

Technical Specifications

Input voltage	240V AC 50Hz Single phase
Motor type	Induction
Motor voltage	240 V AC Three phase
Maximum door size	25m ²
Maximum door height	6000mm
Receiver type	UHF TrioCode™ Receiver
Receiver code storage capacity	511 Transmitters
Transmitter frequency	433 MHz
Coding type	Hopping code
No. of code combinations	Over 4.29 billion random codes
Code generation	Non linear encryption algorithm
Transmitter battery	CR2032
Drive unit weight	23kg

PLEASE NOTE: Specifications are subject to change without notice.





Parts List

When ordering spare parts please quote the order code Number to your installer/dealer

Item/description	order code	Item/description	order code
1. Reducer LM-NEM 50 WV 1/40	14500	38. Int tooth lock washer ID 4	11140
2. AC motor 375W 3P 415V delta	14511	39. Back cover assy (12020201)	62760
3. Chassis assy (12020250)	62775	40. Front cover assy (12020211)	62765
4. Limits housing base (12020291)	16270	41. Hex head screw M8 x 25	10110
5. Microswitch ABV1 22261	69262	42. Spring washer ID 8	10950
6. Nylon cable gland PGB7-07B	65622	43. SER head screw w/washer M4 x 12	10381
7. Helical gear 3005 (12020300)	64044	44. Cable clamp acc-1.5 (3/16")	11750
8. Limit cam red (12020310)	64902	45. Track 62 x 52 x 3 4M (12020140)	64650
9. Limit cam green (12020310)	64912	46. Chain 1/2" x 1/8" (613 links) W/2CL	63003
10. Hex head screw M6 x 65	10266	47. Shuttle trolley (12020340-A)	62654
11. Nilock nut M6	10861	48. Ball bearing 608-2RS1	03882
12. Taptite screw "P" black znc M3 x 16	10550	49. Wheel (12020360)	16395
13. Int tooth lock washer ID 3	11150	50. Disengagement arm (051091)	62610
14. Flat washer ID 6	11040	51. Index finger (051081)	62620
15. Tacho base (12020370)	16390	52. Compression spring 1.2 (051180)	62870
16. PD encode board PDE-1.04	61152	53. E circlip D1500 0070	10815
17. Tacho wheel (12020380)	13926	54. Chain index hex 19 (12020480)	62495
18. Chopper clip (05040230-B)	64960	55. Chain screw right (05020120)	65780
19. Transformer TDB-40-11 kit	62030	56. Chain screw left (05020130)	65770
20. Rail din steel	90202	57. Hex nut M8	10870
20a. Filter CW5C	61922	58. Hex nut (left hand) M8	10930
21. Contractors assy TCRII 3-1 415V	92431	59. Bracket RH (12020400)	62506
21a. Inverter FM50	61920	60. Bracket LH (12020390)	62505
22. CB-14 support (12020320-A)	14014	61. Chain wheel 58 (12020430-A)	62965
23. Axess® PRO C.B ACB03-1.01-100A	61031	62. Bush sleeve (055882)	13860
24. Cover assy CB-14 (12020121)	92578	63. Sprocket 16T x 265 (12020241)	64701
25. Taptite screw "P" black znc M3 x 12	10553	64. Sleeve 081246 (12020410)	64385
26. Taptite screw "P" M4 x 10	10570	65. Hex head screw M8 x 70	10088
27. Terminal block 500/02DS2 pos	65421	66. Flat washer ID 8	11020
28. Terminal block 1500/04DS	65426	67. Nilock nut M8	10860
28a. Terminal block 1500-02	65425	68. Socket set screw M6 x 5	10029
29. Nylon cable gland K16 (M16-10B)	65620	69. Spring washer ID 8	10950
30. Hex head screw M10 x 20	10065		
31. Hex serration head screw M6 x 16	10170		
32. Pan head screw w/washer M5 x 10	10281		
33. Pan head screw M4 x 18	10302		
34. Pan head screw w/washer M4 x 10	10340		
35. Pan head screw w/washer M4 x 8	10320		
36. Pan head screw M3 x 14	10360		
37. Spring washer ID 10	10940		



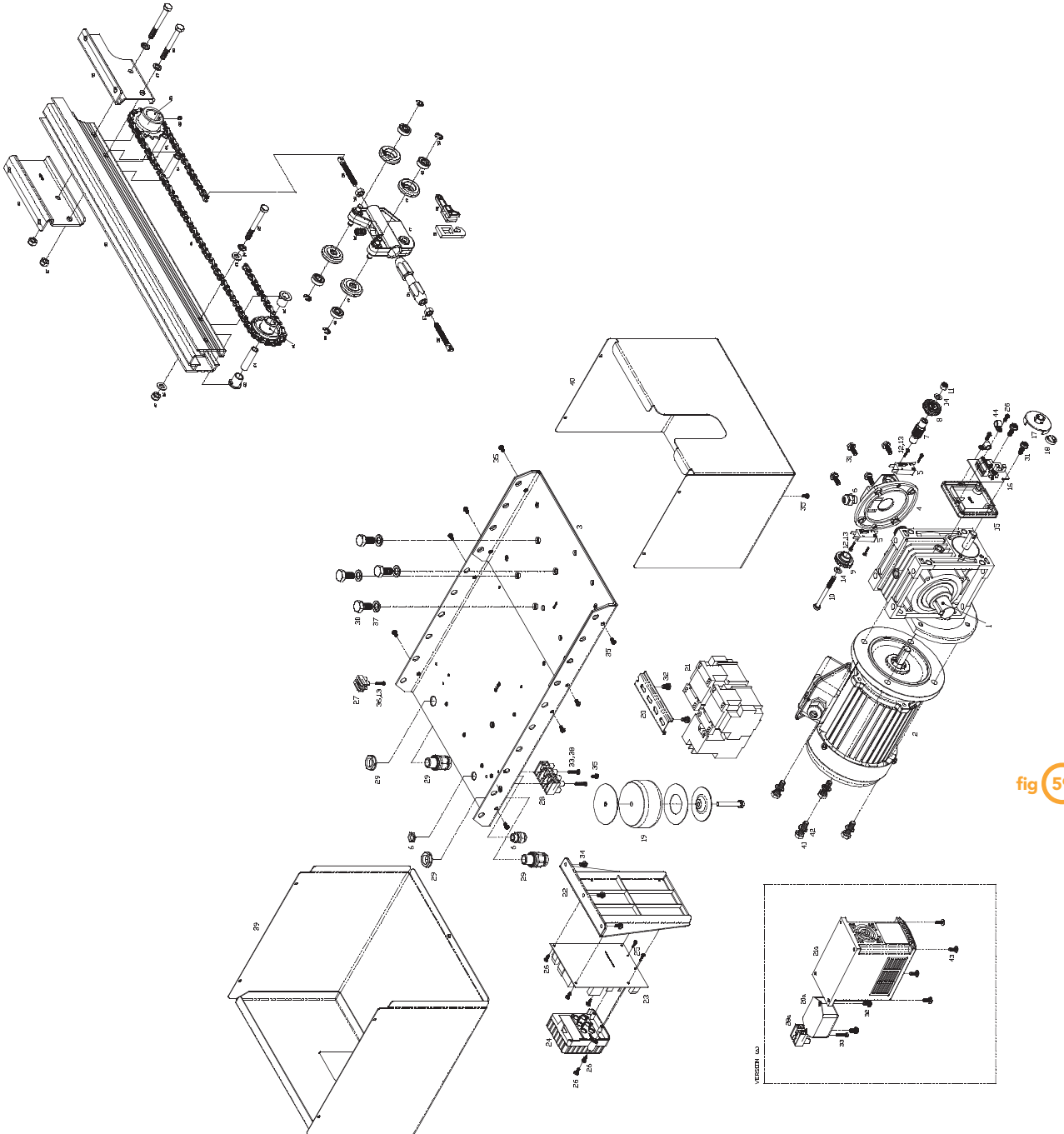

fig 59





Maintenance

Maintenance

Whilst your opener does not require any periodic maintenance, the door that it is fitted to, does. Your door is a large, heavy, moving object and should be tested regularly to ensure it is in good condition. A poorly maintained door could cause fatal or serious injuries or serious damage to property.

To ensure a long and trouble free life for your opener, the following is recommended:

Monthly

- Disengage the opener and manually operate the door: The door must be smooth to operate by hand. An operating force on the bottom rail should not exceed 150N (15kg) force.
- Each month, check that the opener reverses when the door contacts a 40mm high object placed on the floor (AS3350).

NOTE: If the door does not operate smoothly, call your door professional.

Yearly

Automatic Technology suggests you contact your door professional to perform an annual door service.



CAUTION: Frequently examine door, particularly cables, springs and mountings for signs of wear, damage or imbalance. Do not use if repair or adjustment is needed since a fault in the installation or an incorrectly balanced door may cause injury. (AS3350)



Adjustments should only be carried out by door professional, as this function can be dangerous if not performed under strict safety procedures.



WARNING! Failure to maintain your garage door may void the warranty on your garage door opener.

Service Record

Record any maintenance in the following table to assist in any warranty service.

Date	Service by	Signature	Invoice No.	Amount





Notes





Warranty And Exclusion Of Liability

1. This warranty is an addition to any non-excludable conditions or warranties that are implied into this contract by relevant statute, including the Trade Practices Act 1974 (Cth).
2. Subject to all of the matters set out below, Automatic Technology (Australia) Pty Ltd ("ATA") warrants:
 - (a) the Axess® Pro Series Opener for twelve (12) months,
 - (b) all components and accessories for twelve (12) months, from the date of purchase (specified in the sales docket receipt) as free of any defects in material and workmanship.
 - (c) no further warranty will apply for goods repaired in warranty period.
 - (d) for all products repaired outside the warranty period, a six (6) month warranty applies from the date of dispatch.
3. This warranty applies only where the purchaser:
 - (a) immediately notifies ATA or the retailer of the alleged defect;
 - (b) returns the product to the retailer; and
 - (c) presents the relevant sales docket and this warranty document to the retailer to confirm the date of purchase.
4. Except for this warranty, ATA gives no warranties of any kind whatsoever (whether express or implied), in relation to the product, and all warranties of whatsoever kind relating to the product are, to the extent permissible by statute, hereby excluded.
5. To the extent permissible by statute, ATA disclaims any liability of whatsoever nature in respect of any claim or demand for loss or damage which arises out of:
 - a) accidental damage to or normal wear and tear to the product or to the product's components;
 - b) any cost relating to damage resulting from wear and tear;
 - c) blown fuses, loss or damage caused by electrical surges, power surges or power spikes;
 - d) loss or damage due to theft, fire, flood, rain, water, lightning, storms or any other acts of God;
 - e) door surface area exceeding 25m²;
 - f) door not in safe and correct working order and condition;
 - g) evidence of unauthorised repairs;
 - h) any cost relating to damage caused by misuse, negligence or failure to maintain the equipment in a proper working order as per clauses (d) through (i);
 - i) installation, adjustment or use which is not in accordance with the instructions set out in installation instruction manual;
 - j) attempted or complete modification or repairs to the product carried out by a person who is not authorised or has not been trained by ATA to carry out such modification or repairs;
 - k) faulty or unsuitable wiring of structure to which the product is fixed or connected;
 - l) radio (including citizen band transmission) or any electrical interference;
 - m) damage caused by insects;
 - n) loss or damage to any property whatsoever or any loss or expense whatsoever resulting or arising there from or any consequential loss;
 - o) any cost or expense arising due to manufacturer recall of any product;
 - p) any cost or expense due to negligence of the approved service provider;
6. ATA's liability under this warranty is limited, at ATA's absolute option, to replacing or repairing the product which ATA, in its unfettered opinion, considers to be defective either in material and/or workmanship or to credit the dealer with the price at which the product was purchased by the dealer.
7. This warranty does not extend to cover labour for installation.
8. This warranty is limited to Return-to-Base (RTB) repair and does not cover labour for on-site attendance.
9. This warranty is void if the Product is not returned to the manufacturer in original or suitably secure packaging.
10. This warranty is only applicable for repairs to the product carried out within Australia.
11. This warranty does not cover consumable items including globes, batteries and fuses.
12. This warranty is not transferable.
13. This warranty is void if a Photo Electric Beam Sensor is not fitted to the door opening.
14. Where the Product is retailed by any person other than ATA, except for the warranty set out above, such person has no authority from ATA to give any warranty or guarantee on ATA's behalf in addition to the warranty set out above.

NOTES:

1. One (1) cycle = one (1) open and one (1) close action of the door.
2. This warranty is to be read in conjunction with the owner's copy of the installation instruction manual.





© April 2010 Automatic Technology (Australia) Pty Ltd. All rights reserved. Axess® and TrioCode™ are a registered trademark and trademark of Automatic Technology (Australia) Pty Ltd. No part of this document may be reproduced without prior permission. In an ongoing commitment to product quality we reserve the right to change specification without notice. E&OE.

automatic
TECHNOLOGY

smart | simple | secure

an alesco company

Automatic Technology (Australia) Pty Ltd

ABN 11 007 125 368

6-8 Fiveways Boulevard
Keysborough, Victoria, 3173, Australia

P 1300 133 944

+61 3 9791 0200 (International Enquiries Only)

E sales@ata-aust.com.au

www.ata-aust.com.au